

Technical Documentation

# **APH0404**

## **Advantage Plus IEEE Ready | AEHH8R**

Date: June 26, 2020

### Dimensional Drawing

Catalogue	Model	HP	Pole	kW	Rating	Voltage	Hz	RPM
APH0404	AEHH8R	40	4	30	Continuous	460	60	1800

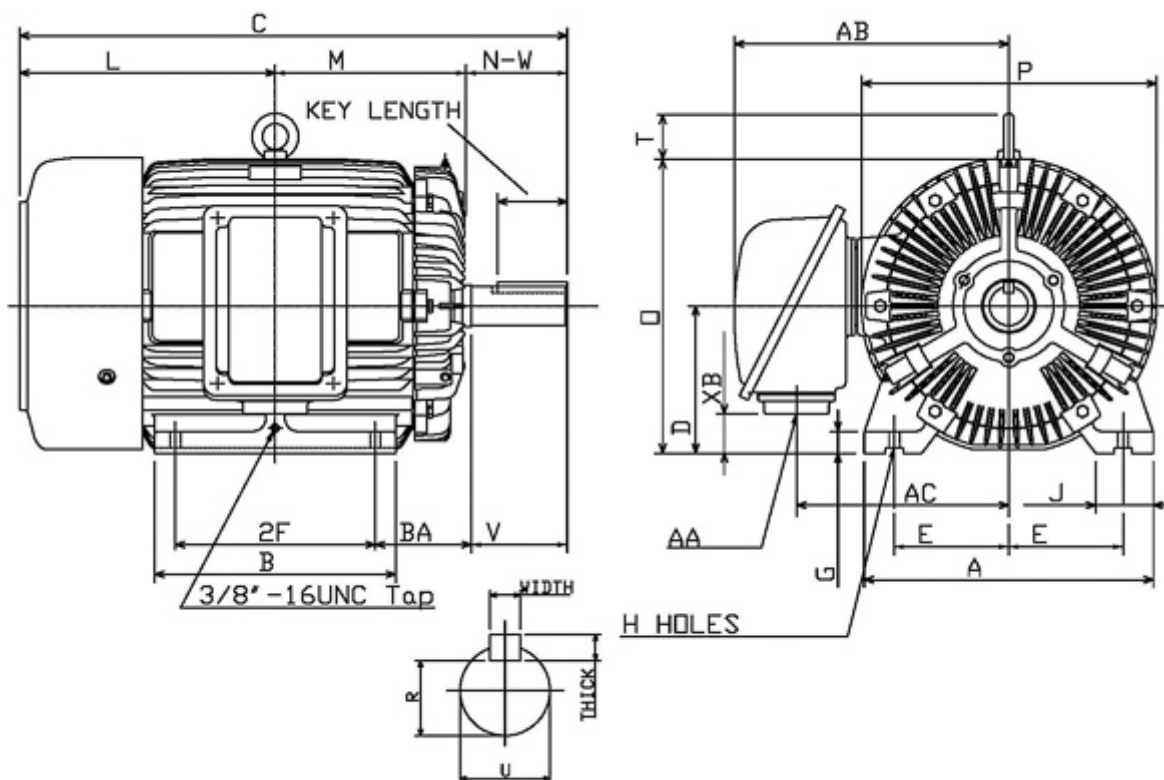

Frame Size	Mounting					A	B	C	CD	D	
	E	2F	2F2	H	BA						
324T	6.25	10.5		0.66	5.25	15.75	12.8	29.93		8	
G	J	K	L	M	O	P	T	Key			Keyseat
1.1	3.15		14.18	10.1	16.22	16.55	2.36	Width	Thick	Length	R
								0.5	0.5	3.91	1.845
Terminal Housing			Aux Box			C/D Flange					
AA	AB	AC	XB	AE	AX	BB	AH	AK	BD	AJ	BF
NPT2"	14.72	11.3	3.59								
Shaft Extension			Bearings		Approx. Weight Lbs	SPL dBA/3ft	Ins. Class	S.F.	Drive Method	Dimensions	
N-W	U	V	DE	NDE							
5.25	2.125	5.15	6312ZC3	6212ZC3	638	74	F	1.15	Direct Coupling / Belt Drive	Inches	

	
	Date: June 26, 2020

### Technical Data Sheet

Motor Type: AEHH8R	Catalogue No: APH0404
--------------------	-----------------------

#### Nameplate Information

HP	Pole	RPM	Frame	Voltage	Hz	Phase
40	4	1770	324T	460	60	3
Enclosure	Ins. Class	Service Factor	Time Rating	NEMA Design	Rated Amb.	Rated Altitude
TEFC	F	1.15	Continuous	B	-40 to 40 °C	<1000 m

#### Typical Performance

Efficiency (%)				Power Factor (%)		
Full Load		3/4 Load	1/2 Load	Full Load	3/4 Load	1/2 Load
Nom.	Min.					
94.1	93.0	94.5	94.5	86.0	84.5	78.5
Torque				Current (A)		
Full Load (lb-ft)	Locked Rotor (% FLT)	Pull Up (% FLT)	Break Down (% FLT)	No Load	Full Load	Locked Rotor
118.70	205	170	220	10.6	46.3	290
NEMA KVA Code	Inertia (WR <sup>2</sup> )			Safe Stall Time (s)		Noise Level Sound Press. dB(A)
	Rotor (lb-ft <sup>2</sup> )	NEMA Load (lb-ft <sup>2</sup> )	Max. Allowable (lb-ft <sup>2</sup> )	Cold	Hot	
G	8.624	189.00	375.00	25	18	74

#### VFD Duty Information

Speed Range			VFD		S.F.
Constant Torque	Variable Torque	Constant Power	Carrier	Type	
6-60Hz	3-60Hz	60-90Hz	≤ 5 kHz	VPWM or CPWM	1.0 Only

#### Hazardous Locations Information

CSA Certified
Class I, Div 2, Groups B, C & D Class I, Zone 2, Groups IIB+H2, IIB & IIA
Temp Code (Sinewave / VFD)
T3C / T3B

#### Additional Certifications

Other Certification
Class II, Div 2, Groups F & G

#### Additional Information

Bearings		Approx. Weight
DE	NDE	lbs
6312ZC3	6212ZC3	638

**Nameplate Drawing**

# Advantage Plus IEEE Ready

TYPE	AEHH8R	CAT. NO.	APH0404		
OUTPUT	40 HP 30 kW	FRAME	324T	TEFC	
R.P.M.	1770	POLE	4	INS.	F
VOLTS	460	PHASE	3	Hz	60
AMPS	46.3	CODE	G	S.F.	1.15
AMBIENT	40 °C	NOM. EFF. 94.1		MIN. EFF. 93.0	
BEARINGS	6312ZC3 / 6212ZC3			RATING Cont.	
SER. NO.	TBD	DESIGN	B	WT. 638 LBS	
PWM VFD DUTY	VT	CT	CP	S.F.	
	3-60Hz	6-60Hz	60-90Hz	1.0 Only	

**Connection Diagram**



3 LEAD		SINGLE VOLTAGE			DELTA
VOLTAGE	CONN.	L1	L2	L3	
-	DELTA	1	2	3	

WD\_3D

**Thermal Limit Curves**

Motor Type: AEHH8R		Catalogue No: APH0404		Family: Advantage Plus IEEE Ready	
HP	40	Safe Stall Time		Full Load A	46.3 A
Voltage	460V 60Hz	Hot	18 s	% Inrush	627 %
RPM	1800	Cold	25 s	Locked Rotor A	290 A

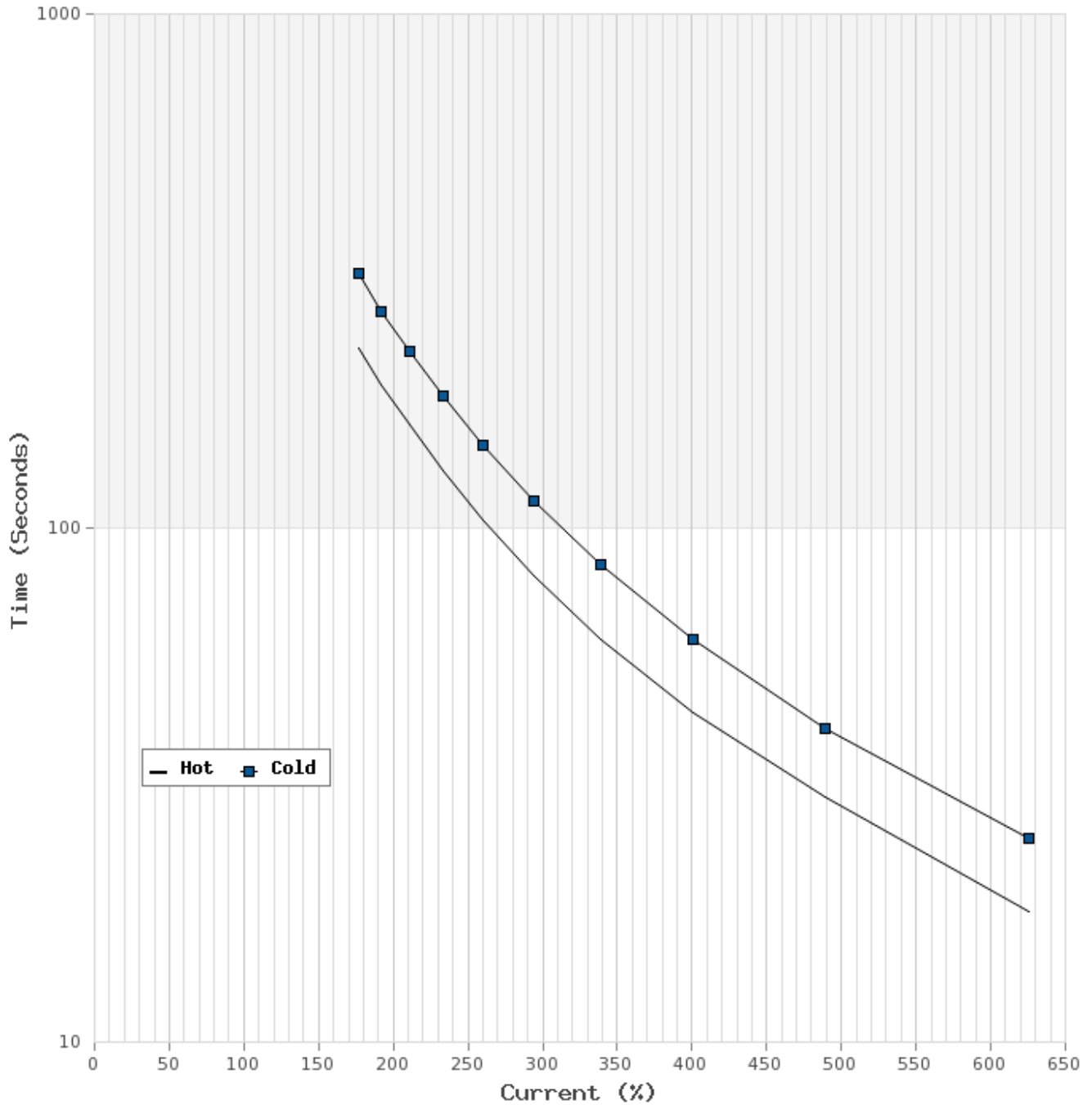

**T-N and I-N Curves**

Motor Type: AEHH8R		Catalogue No: APH0404		Family: Advantage Plus IEEE Ready	
HP	40	Full Load T	118.70 lb-ft	Full Load A	46.3 A
Voltage	460V 60Hz	Locked Rotor T	205 %	Locked Rotor A	290.0 A
RPM	1800	Pull Up T	170 %	Break Down T	220 %

