

Technical Documentation

APH1254-841
Advantage Plus IEEE 841 | AEHH8B

Date: June 29, 2020

Dimensional Drawing

Catalogue	Model	HP	Pole	kW	Rating	Voltage	Hz	RPM
APH1254-841	AEHH8B	125	4	93	Continuous	460	60	1800

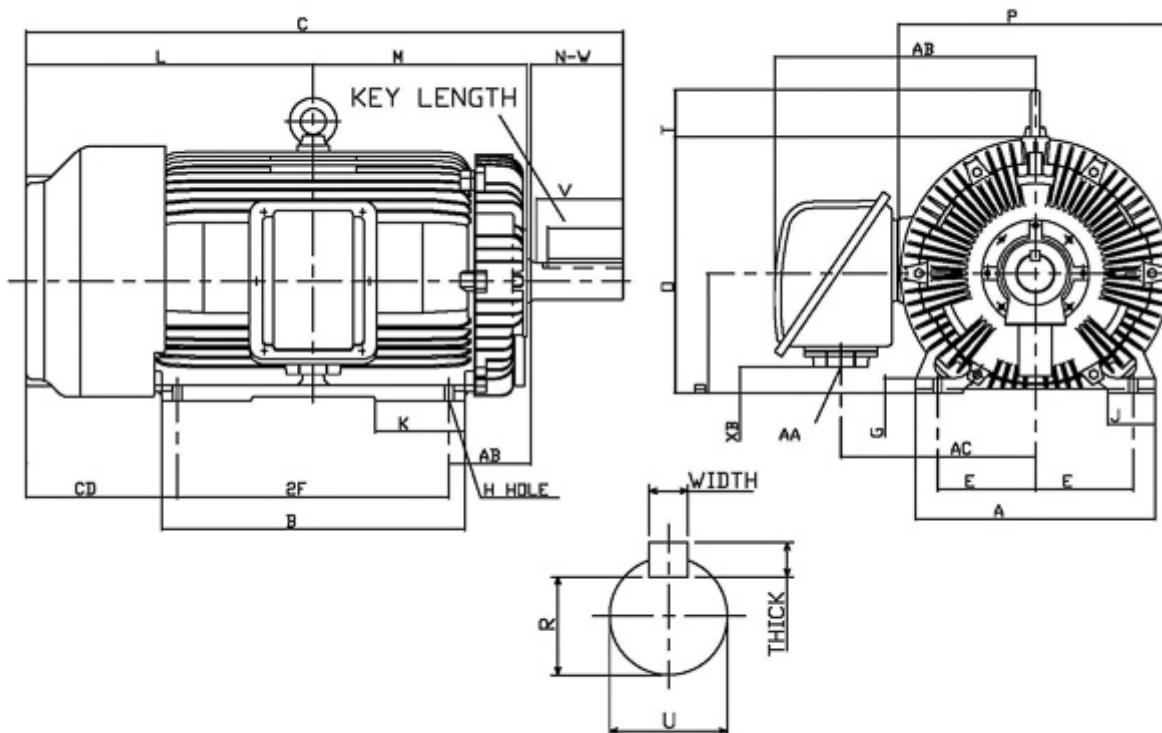

Frame Size	Mounting					A	B	C	CD	D	
	E	2F	2F2	H	BA						
444T	9	14.5		0.81	7.5	22.05	17.5	44.4		11	
G	J	K	L	M	O	P	T	Key			Keyseat
1.4	4.35	4.35	21.15	14.4	23.55	24.75	4.35	Width	Thick	Length	R
								0.875	0.875	6.91	2.88
Terminal Housing			Aux Box			C/D Flange					
AA	AB	AC	XB	AE	AX	BB	AH	AK	BD	AJ	BF
NPT3"	24	17.9	2.4								
Shaft Extension			Bearings		Approx. Weight Lbs	SPL dBA/3ft	Ins. Class	S.F.	Drive Method	Dimensions	
N-W	U	V	DE	NDE							
8.5	3.375	8	6318C3	6316C3	1716	81	F	1.15	Direct Coupling / Belt Drive	Inches	

	
	Date: June 29, 2020

Technical Data Sheet

Motor Type: AEHH8B	Catalogue No: APH1254-841
--------------------	---------------------------

Nameplate Information

HP	Pole	RPM	Frame	Voltage	Hz	Phase
125	4	1780	444T	460	60	3
Enclosure	Ins. Class	Service Factor	Time Rating	NEMA Design	Rated Amb.	Rated Altitude
TEFC	F	1.15	Continuous	B	-40 to 40 °C	<1000 m

Typical Performance

Efficiency (%)				Power Factor (%)		
Full Load		3/4 Load	1/2 Load	Full Load	3/4 Load	1/2 Load
Nom.	Min.					
95.4	94.5	95.0	94.1	84.0	82.0	77.0
Torque				Current (A)		
Full Load (lb-ft)	Locked Rotor (% FLT)	Pull Up (% FLT)	Break Down (% FLT)	No Load	Full Load	Locked Rotor
368.00	130	100	220	37.9	146.1	908
NEMA KVA Code	Inertia (WR ²)			Safe Stall Time (s)		Noise Level Sound Press. dB(A)
	Rotor (lb-ft ²)	NEMA Load (lb-ft ²)	Max. Allowable (lb-ft ²)	Cold	Hot	
G	44.300	542.00	1084.00	24	17	81

VFD Duty Information

Speed Range			VFD		S.F.
Constant Torque	Variable Torque	Constant Power	Carrier	Type	
12-60Hz	3-60Hz	60-90Hz	≤ 5 kHz	VPWM or CPWM	1.0 Only

Hazardous Locations Information

CSA Certified
Class I, Div 2, Groups B, C & D Class I, Zone 2, Groups IIB+H2, IIB & IIA
Temp Code (Sinewave / VFD)
T3C / T3

Additional Certifications

Other Certification

Additional Information

Bearings		Approx. Weight
DE	NDE	lbs
6318C3	6316C3	1716

Nameplate Drawing

Advantage Plus IEEE 841

TYPE	AEHH8B	CAT. NO.	APH1254-841		
OUTPUT	125 HP 93 kW	FRAME	444T	TEFC	
R.P.M.	1780	POLE	4	INS.	F
VOLTS	460	PHASE	3	Hz	60
AMPS	146.1	CODE	G	S.F.	1.15
AMBIENT	40 °C	NOM. EFF. 95.4		MIN. EFF. 94.5	
BEARINGS	6318C3 / 6316C3			RATING Cont.	
SER. NO.	TBD	DESIGN	B	WT. 1716 LBS	
PWM VFD DUTY	VT	CT	CP	S.F.	
	3-60Hz	12-60Hz	60-90Hz	1.0 Only	

Connection Diagram



3 LEAD		SINGLE VOLTAGE			DELTA
VOLTAGE	CONN.	L1	L2	L3	
-	DELTA	1	2	3	

WD_3D

Thermal Limit Curves

Motor Type: AEHH8B		Catalogue No: APH1254-841		Family: Advantage Plus IEEE 841	
HP	125	Safe Stall Time		Full Load A	146.1 A
Voltage	460V 60Hz	Hot	17 s	% Inrush	622 %
RPM	1800	Cold	24 s	Locked Rotor A	908 A

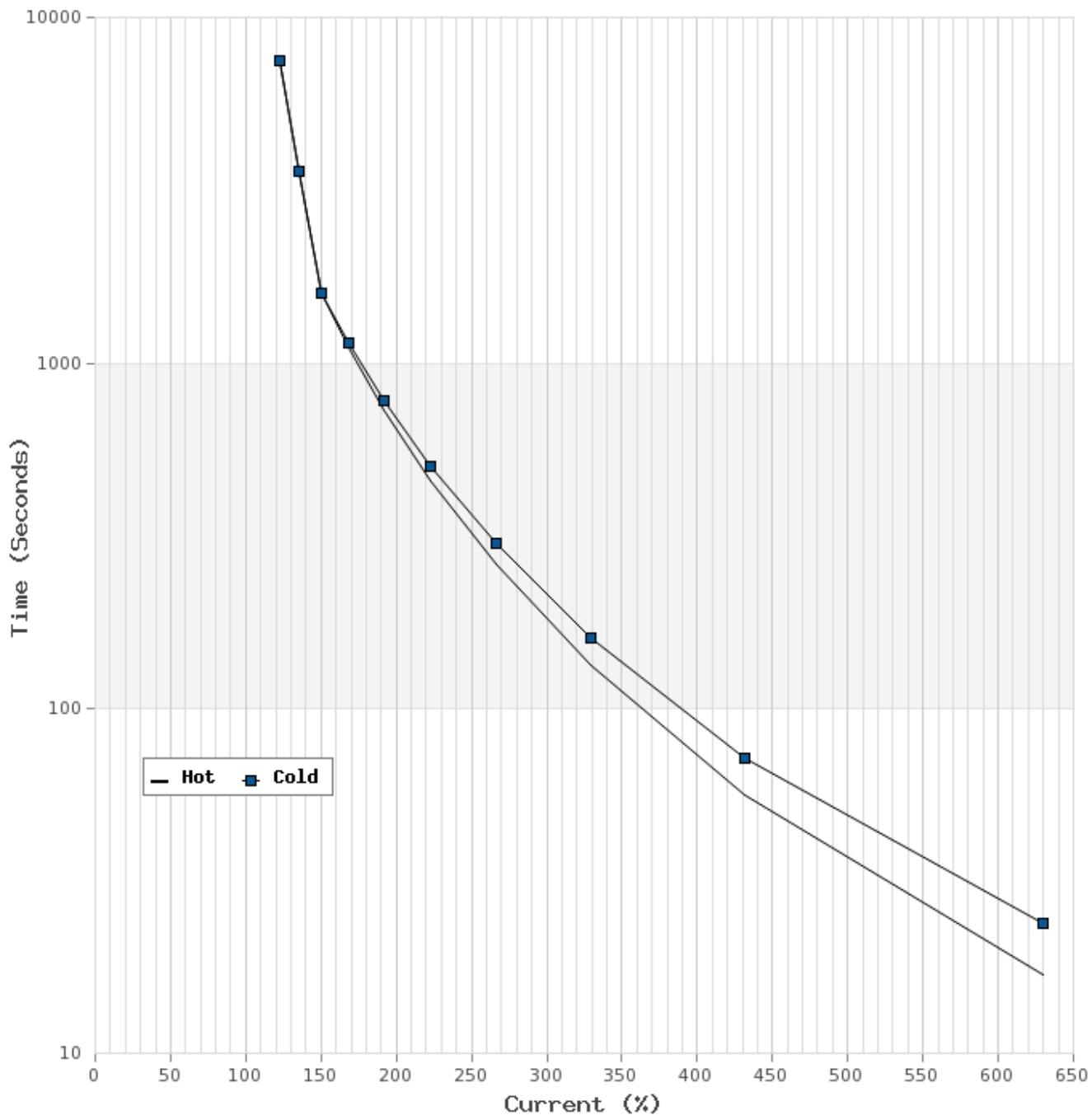

T-N and I-N Curves

Motor Type: AEHH8B		Catalogue No: APH1254-841		Family: Advantage Plus IEEE 841	
HP	125	Full Load T	368.00 lb-ft	Full Load A	146.1 A
Voltage	460V 60Hz	Locked Rotor T	130 %	Locked Rotor A	908.0 A
RPM	1800	Pull Up T	100 %	Break Down T	220 %

