

Technical Documentation

APH3504L-841
Advantage Plus IEEE 841 | AEHH8B

Date: June 29, 2020

Dimensional Drawing

Catalogue	Model	HP	Pole	kW	Rating	Voltage	Hz	RPM
APH3504L-841	AEHH8B	350	4	261	Continuous	460	60	1800

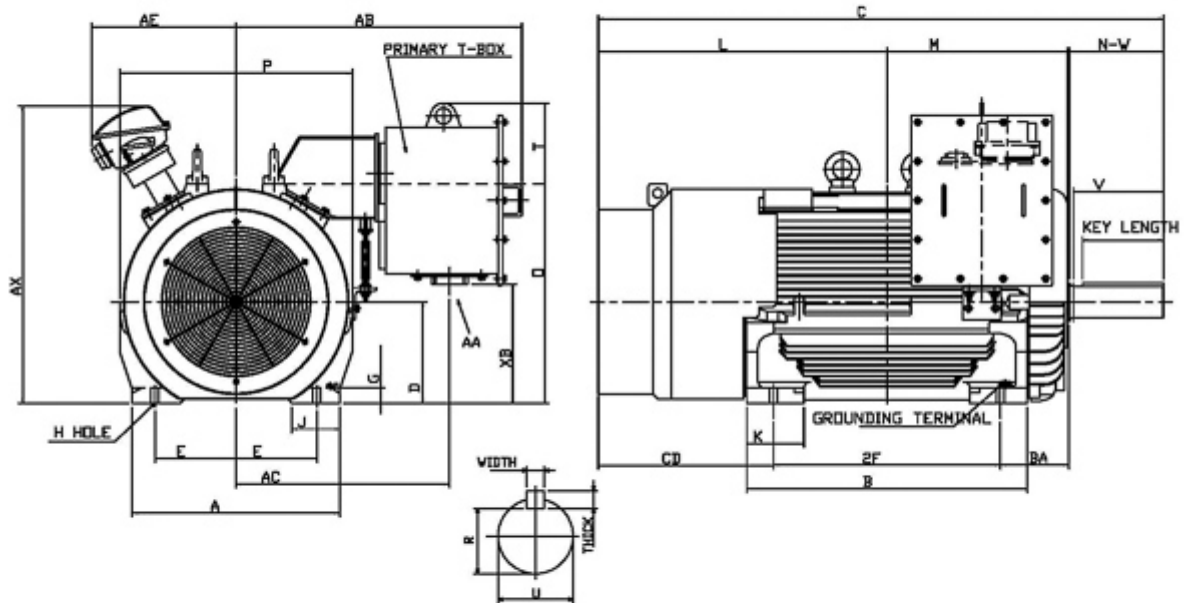

Frame Size	Mounting					A	B	C	CD	D	
	E	2F	2F2	H	BA						
5009B	10	28		0.94	8.5	25.6	34.65	69.75		12.5	
G	J	K	L	M	O	P	T	Key			Keyseat
1.85	5.9	7.1	35.63	22.1	27.07	28.75	14.7	Width	Thick	Length	R
								1	1	10	3.309
Terminal Housing			Aux Box			C/D Flange					
AA	AB	AC	XB	AE	AX	BB	AH	AK	BD	AJ	BF
	36.95	24.8	14.67	17.83	36.67						
Shaft Extension			Bearings		Approx. Weight Lbs	SPL dBA/3ft	Ins. Class	S.F.	Drive Method	Dimensions	
N-W	U	V	DE	NDE							
11.62	3.875	11.12	6324C3	6320C3	4026	81	F	1.15	Direct Coupling	Inches	

	
	Date: June 29, 2020

Technical Data Sheet

Motor Type: AEHH8B	Catalogue No: APH3504L-841
--------------------	----------------------------

Nameplate Information

HP	Pole	RPM	Frame	Voltage	Hz	Phase
350	4	1785	5009B	460	60	3
Enclosure	Ins. Class	Service Factor	Time Rating	NEMA Design	Rated Amb.	Rated Altitude
TEFC	F	1.15	Continuous	B	-40 to 40 °C	<1000 m

Typical Performance

Efficiency (%)				Power Factor (%)		
Full Load		3/4 Load	1/2 Load	Full Load	3/4 Load	1/2 Load
Nom.	Min.					
96.2	95.5	95.8	93.8	90.0	89.0	84.0
Torque				Current (A)		
Full Load (lb-ft)	Locked Rotor (% FLT)	Pull Up (% FLT)	Break Down (% FLT)	No Load	Full Load	Locked Rotor
1028.00	100	100	220	69.2	378.5	2550
NEMA KVA Code	Inertia (WR ²)			Safe Stall Time (s)		Noise Level Sound Press. dB(A)
	Rotor (lb-ft ²)	NEMA Load (lb-ft ²)	Max. Allowable (lb-ft ²)	Cold	Hot	
G	138.000	1373.00	1373.00	19	14	81

VFD Duty Information

Speed Range			VFD		S.F.
Constant Torque	Variable Torque	Constant Power	Carrier	Type	
20-60Hz	3-60Hz	60-60Hz	≤ 5 kHz	VPWM or CPWM	1.0 Only

Hazardous Locations Information

CSA Certified
Class I, Div 2, Groups B, C & D Class I, Zone 2, Groups IIB+H2, IIB & IIA
Temp Code (Sinewave / VFD) T3 / T3

Additional Certifications

Other Certification

Additional Information

Bearings		Approx. Weight
DE	NDE	lbs
6324C3	6320C3	4026

Nameplate Drawing

Advantage Plus IEEE 841

TYPE	AEHH8B	CAT. NO.	APH3504L-841		
OUTPUT	350 HP 261 kW	FRAME	5009B	TEFC	
R.P.M.	1785	POLE	4	INS.	F
VOLTS	460	PHASE	3	Hz	60
AMPS	378.5	CODE	G	S.F.	1.15
AMBIENT	40 °C	NOM. EFF. 96.2		MIN. EFF. 95.5	
BEARINGS	6324C3 / 6320C3			RATING Cont.	
SER. NO.	TBD	DESIGN	B	WT. 4026 LBS	
PWM VFD DUTY	VT	CT	CP	S.F.	
	3-60Hz	20-60Hz	60-60Hz	1.0 Only	

Connection Diagram



3 LEAD		SINGLE VOLTAGE			DELTA
VOLTAGE	CONN.	L1	L2	L3	
-	DELTA	1	2	3	

WD_3D

Thermal Limit Curves

Motor Type: AEHH8B		Catalogue No: APH3504L-841		Family: Advantage Plus IEEE 841	
HP	350	Safe Stall Time		Full Load A	378.5 A
Voltage	460V 60Hz	Hot	14 s	% Inrush	674 %
RPM	1800	Cold	19 s	Locked Rotor A	2550 A

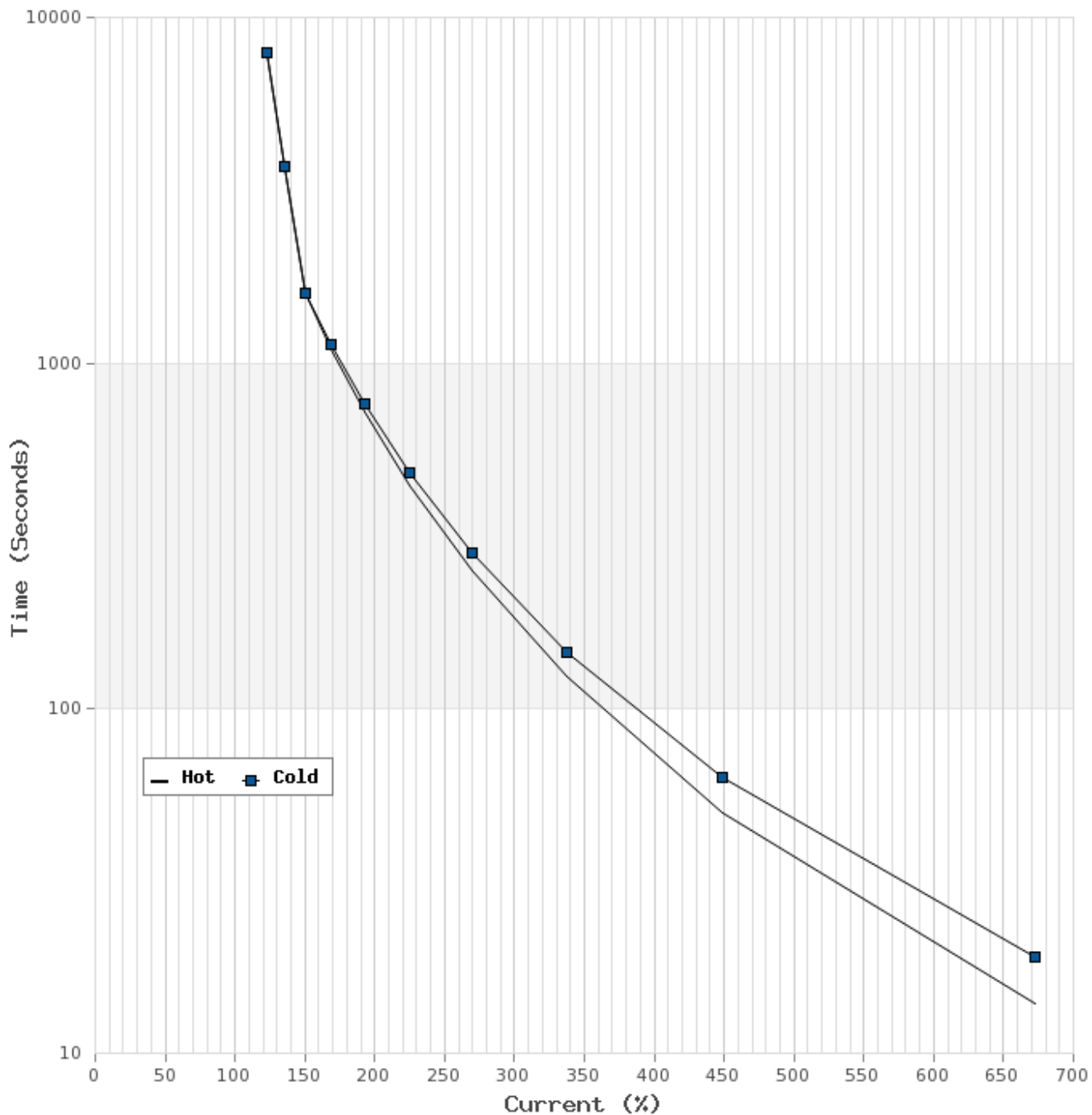

T-N and I-N Curves

Motor Type: AEHH8B		Catalogue No: APH3504L-841		Family: Advantage Plus IEEE 841	
HP	350	Full Load T	1028.00 lb-ft	Full Load A	378.5 A
Voltage	460V 60Hz	Locked Rotor T	100 %	Locked Rotor A	2550.0 A
RPM	1800	Pull Up T	100 %	Break Down T	220 %

