

Technical Documentation

APH01065
Advantage Plus IEEE Ready | AEHH8R

Date: June 26, 2020

Dimensional Drawing

Catalogue	Model	HP	Pole	kW	Rating	Voltage	Hz	RPM
APH01065	AEHH8R	10	6	7	Continuous	575	60	1200

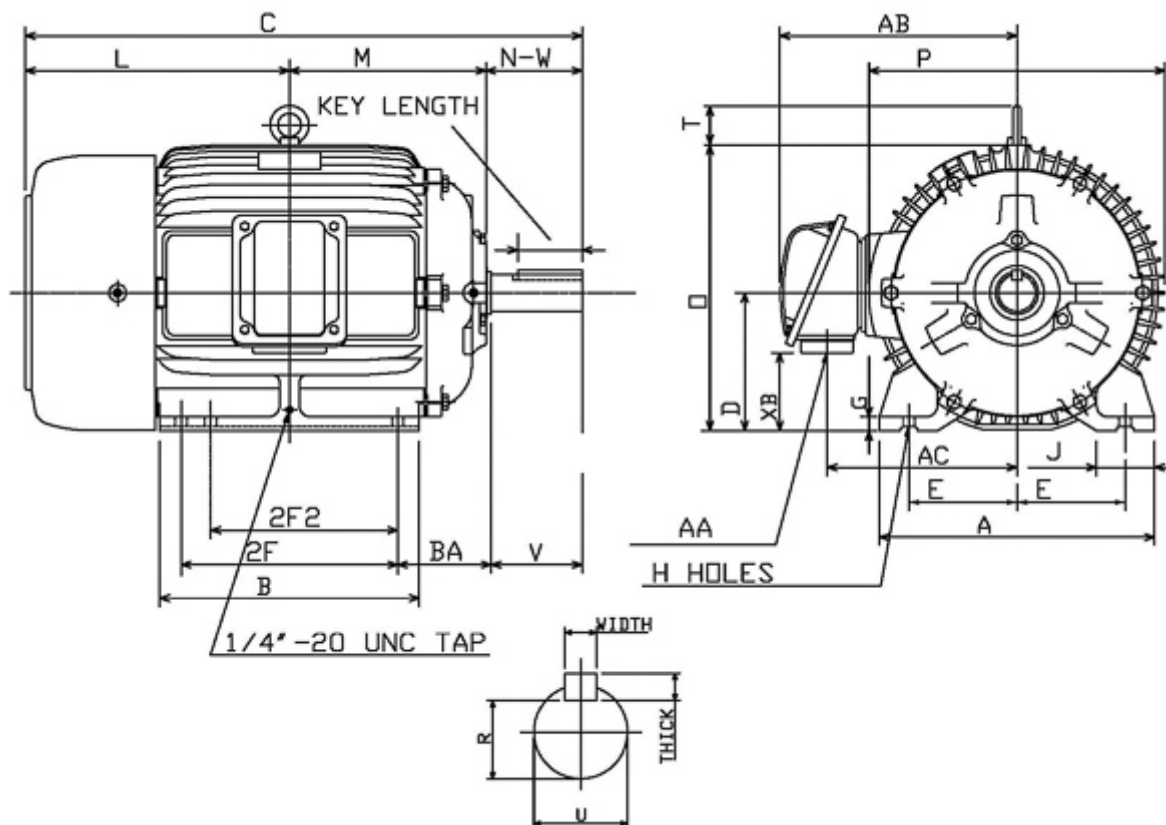

Frame Size	Mounting					A	B	C	CD	D	
	E	2F	2F2	H	BA						
256T	5	10	8.25	0.53	4.25	11.81	11.81	25.52		6.25	
G	J	K	L	M	O	P	T	Key			Keyseat
0.66	1.95		12.27	8.93	12.8	13.15	2.01	Width	Thick	Length	R
								0.375	0.375	2.91	1.416
Terminal Housing			Aux Box			C/D Flange					
AA	AB	AC	XB	AE	AX	BB	AH	AK	BD	AJ	BF
NPT11/4"	11.3	8.86	3.22								
Shaft Extension			Bearings		Approx. Weight Lbs	SPL dBA/3ft	Ins. Class	S.F.	Drive Method	Dimensions	
N-W	U	V	DE	NDE							
4	1.625	3.9	6309ZC3	6307ZC3	337	60	F	1.15	Direct Coupling / Belt Drive	Inches	

	
	Date: June 26, 2020

Technical Data Sheet

Motor Type: AEHH8R	Catalogue No: APH01065
--------------------	------------------------

Nameplate Information

HP	Pole	RPM	Frame	Voltage	Hz	Phase
10	6	1170	256T	575	60	3
Enclosure	Ins. Class	Service Factor	Time Rating	NEMA Design	Rated Amb.	Rated Altitude
TEFC	F	1.15	Continuous	B	-40 to 40 °C	<1000 m

Typical Performance

Efficiency (%)				Power Factor (%)		
Full Load		3/4 Load	1/2 Load	Full Load	3/4 Load	1/2 Load
Nom.	Min.					
91.0	89.5	91.7	90.2	80.5	75.0	64.0
Torque				Current (A)		
Full Load (lb-ft)	Locked Rotor (% FLT)	Pull Up (% FLT)	Break Down (% FLT)	No Load	Full Load	Locked Rotor
44.87	225	185	250	4.7	10.2	65
NEMA KVA Code	Inertia (WR ²)			Safe Stall Time (s)		Noise Level Sound Press. dB(A)
	Rotor (lb-ft ²)	NEMA Load (lb-ft ²)	Max. Allowable (lb-ft ²)	Cold	Hot	
H	2.872	137.00	362.00	26	18	60

VFD Duty Information

Speed Range			VFD		S.F.
Constant Torque	Variable Torque	Constant Power	Carrier	Type	
6-60Hz	3-60Hz	60-120Hz	≤ 5 kHz	VPWM or CPWM	1.0 Only

Hazardous Locations Information

CSA Certified
Class I, Div 2, Groups B, C & D Class I, Zone 2, Groups IIB+H2, IIB & IIA
Temp Code (Sinewave / VFD)
T3C / T3B

Additional Certifications

Other Certification
Class II, Div 2, Groups F & G

Additional Information

Bearings		Approx. Weight
DE	NDE	lbs
6309ZC3	6307ZC3	337

Nameplate Drawing

Advantage Plus IEEE Ready

TYPE	AEHH8R	CAT. NO.	APH01065		
OUTPUT	10 HP 7 kW	FRAME	256T	TEFC	
R.P.M.	1170	POLE	6	INS.	F
VOLTS	575	PHASE	3	Hz	60
AMPS	10.2	CODE	H	S.F.	1.15
AMBIENT	40 °C	NOM. EFF. 91.0		MIN. EFF. 89.5	
BEARINGS	6309ZC3 / 6307ZC3			RATING Cont.	
SER. NO.	TBD	DESIGN	B	WT. 337 LBS	
PWM VFD DUTY	VT	CT	CP	S.F.	
	3-60Hz	6-60Hz	60-120Hz	1.0 Only	

Connection Diagram



3 LEAD		SINGLE VOLTAGE			DELTA
VOLTAGE	CONN.	L1	L2	L3	
-	DELTA	1	2	3	

WD_3D

Thermal Limit Curves

Motor Type: AEHH8R		Catalogue No: APH01065		Family: Advantage Plus IEEE Ready	
HP	10	Safe Stall Time		Full Load A	10.2 A
Voltage	575V 60Hz	Hot	18 s	% Inrush	635 %
RPM	1200	Cold	26 s	Locked Rotor A	65 A

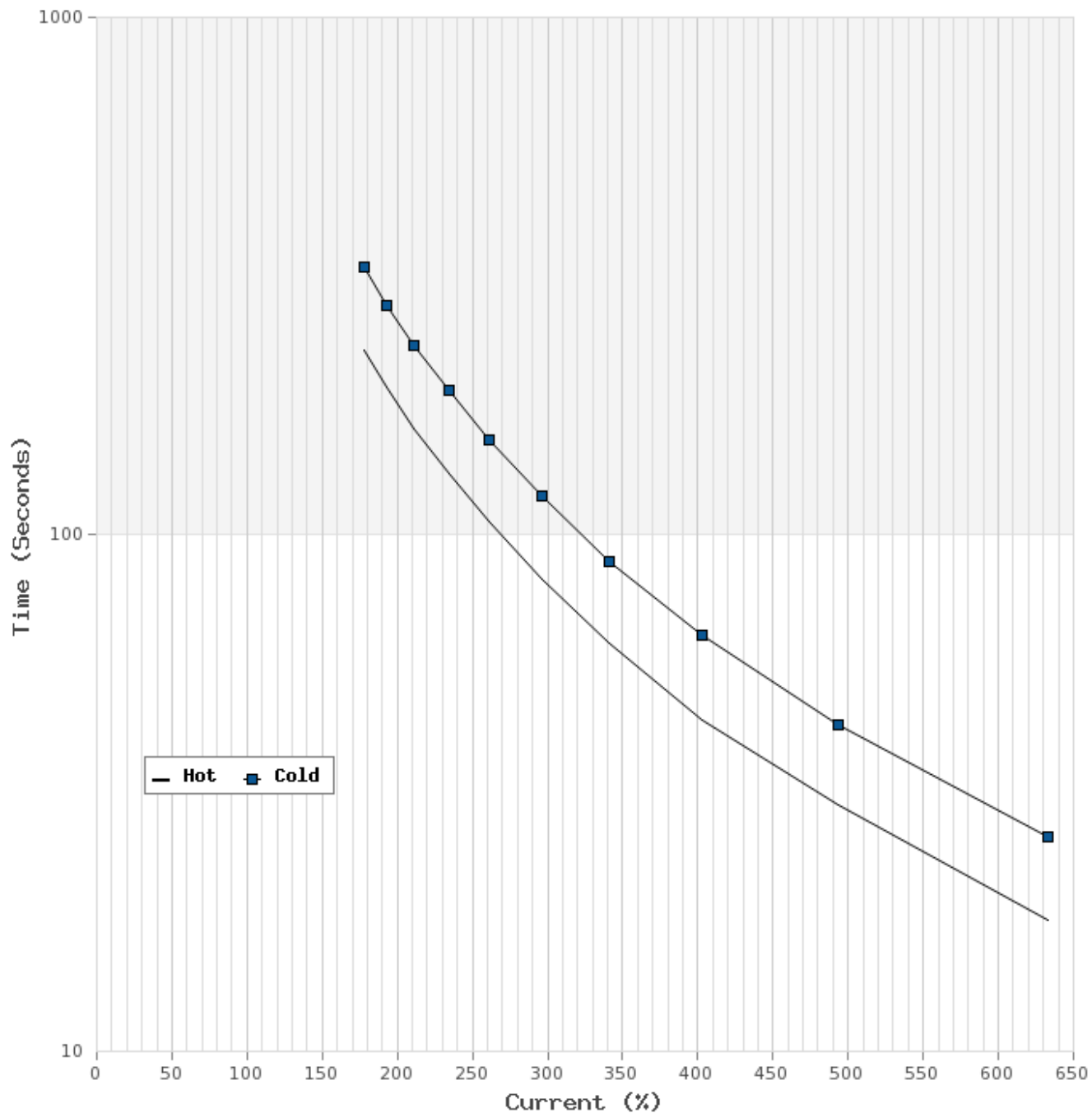

T-N and I-N Curves

Motor Type: AEHH8R		Catalogue No: APH01065		Family: Advantage Plus IEEE Ready	
HP	10	Full Load T	44.87 lb-ft	Full Load A	10.2 A
Voltage	575V 60Hz	Locked Rotor T	225 %	Locked Rotor A	65.0 A
RPM	1200	Pull Up T	185 %	Break Down T	250 %

