

Technical Documentation

# **APH1/54**

## **Advantage Plus IEEE Ready | AEHH8R**

Date: June 25, 2020

### Dimensional Drawing

Catalogue	Model	HP	Pole	kW	Rating	Voltage	Hz	RPM
APH1/54	AEHH8R	1.5	4	1.1	Continuous	460	60	1800

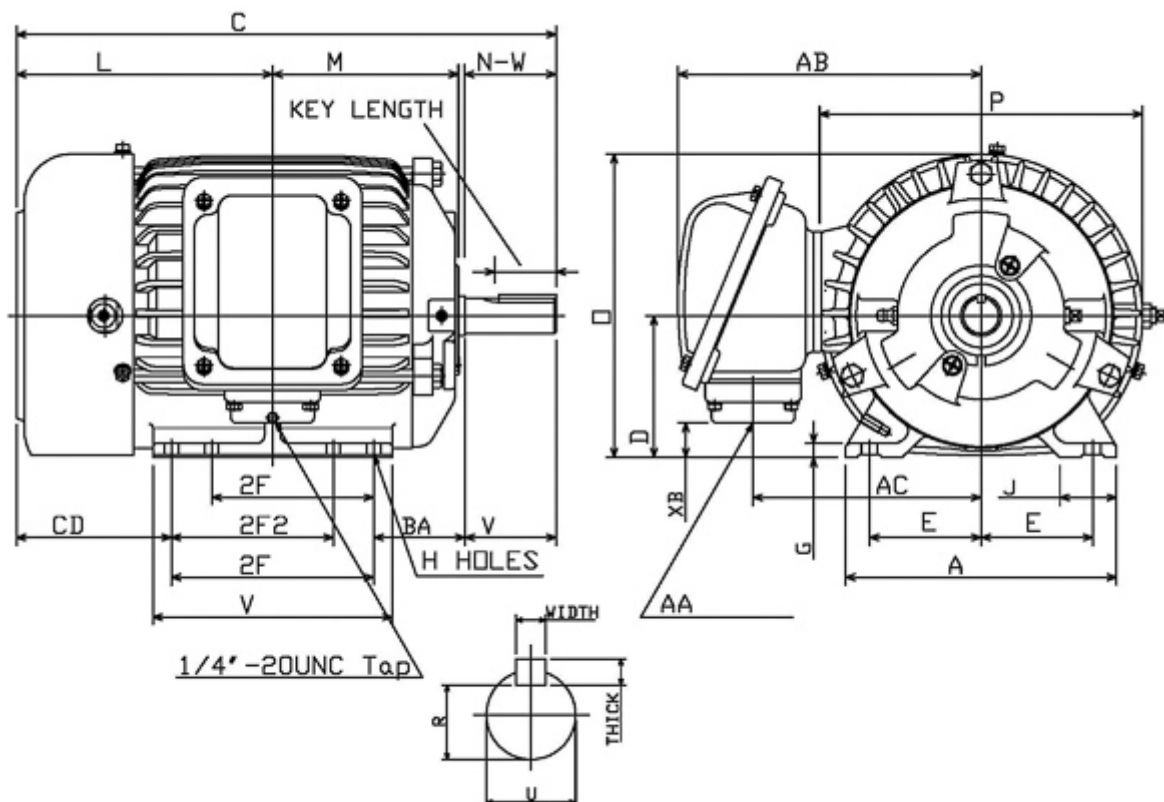

Frame Size	Mounting					A	B	C	CD	D	
	E	2F	2F2	H	BA						
145T	2.75	5	4	0.34	2.25	6.7	5.1	13.54		3.5	
G	J	K	L	M	O	P	T	Key			Keyseat
0.35	1.4		6.54	4.53	7.48	7.95		Width	Thick	Length	R
								0.188	0.188	1.41	0.771
Terminal Housing			Aux Box			C/D Flange					
AA	AB	AC	XB	AE	AX	BB	AH	AK	BD	AJ	BF
NPT3/4"	7.56	5.63	0.86								
Shaft Extension			Bearings		Approx. Weight Lbs	SPL dBA/3ft	Ins. Class	S.F.	Drive Method	Dimensions	
N-W	U	V	DE	NDE							
2.25	0.875	2.2	6205ZC3	6205ZC3	62	50	F	1.15	Direct Coupling / Belt Drive	Inches	

	
	Date: June 25, 2020

### Technical Data Sheet

Motor Type: AEHH8R	Catalogue No: APH1/54
--------------------	-----------------------

#### Nameplate Information

HP	Pole	RPM	Frame	Voltage	Hz	Phase
1.5	4	1730	145T	460	60	3
Enclosure	Ins. Class	Service Factor	Time Rating	NEMA Design	Rated Amb.	Rated Altitude
TEFC	F	1.15	Continuous	B	-40 to 40 °C	<1000 m

#### Typical Performance

Efficiency (%)				Power Factor (%)		
Full Load		3/4 Load	1/2 Load	Full Load	3/4 Load	1/2 Load
Nom.	Min.					
86.5	84.0	86.5	85.5	78.0	70.0	57.0
Torque				Current (A)		
Full Load (lb-ft)	Locked Rotor (% FLT)	Pull Up (% FLT)	Break Down (% FLT)	No Load	Full Load	Locked Rotor
4.55	300	260	360	1.1	2.1	20
NEMA KVA Code	Inertia (WR <sup>2</sup> )			Safe Stall Time (s)		Noise Level Sound Press. dB(A)
	Rotor (lb-ft <sup>2</sup> )	NEMA Load (lb-ft <sup>2</sup> )	Max. Allowable (lb-ft <sup>2</sup> )	Cold	Hot	
M	0.093	8.60	47.00	57	40	50

#### VFD Duty Information

Speed Range			VFD		S.F.
Constant Torque	Variable Torque	Constant Power	Carrier	Type	
6-60Hz	3-60Hz	60-120Hz	≤ 5 kHz	VPWM or CPWM	1.0 Only

#### Hazardous Locations Information

CSA Certified
Class I, Div 2, Groups B, C & D Class I, Zone 2, Groups IIB+H2, IIB & IIA
Temp Code (Sinewave / VFD)
T3C / T3C

#### Additional Certifications

Other Certification
Class II, Div 2, Groups F & G

#### Additional Information

Bearings		Approx. Weight
DE	NDE	lbs
6205ZC3	6205ZC3	62

**Nameplate Drawing**

# Advantage Plus IEEE Ready

TYPE	AEHH8R	CAT. NO.	APH1/54		
OUTPUT	1.5 HP 1.1 kW	FRAME	145T	TEFC	
R.P.M.	1730	POLE	4	INS.	F
VOLTS	460	PHASE	3	Hz	60
AMPS	2.1	CODE	M	S.F.	1.15
AMBIENT	40 °C	NOM. EFF. 86.5		MIN. EFF. 84.0	
BEARINGS	6205ZC3 / 6205ZC3			RATING Cont.	
SER. NO.	TBD	DESIGN	B	WT. 62 LBS	
PWM VFD DUTY	VT	CT	CP	S.F.	
	3-60Hz	6-60Hz	60-120Hz	1.0 Only	

**Connection Diagram**

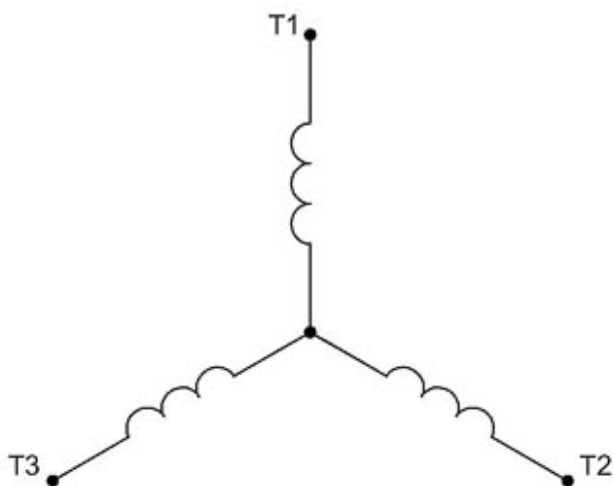

3 LEAD		SINGLE VOLTAGE			WYE
VOLTAGE	CONN.	L1	L2	L3	
-	WYE	1	2	3	

WD\_3Y

**Thermal Limit Curves**

Motor Type: AEHH8R		Catalogue No: APH1/54		Family: Advantage Plus IEEE Ready	
HP	1.5	Safe Stall Time		Full Load A	2.1 A
Voltage	460V 60Hz	Hot	40 s	% Inrush	962 %
RPM	1800	Cold	57 s	Locked Rotor A	20 A

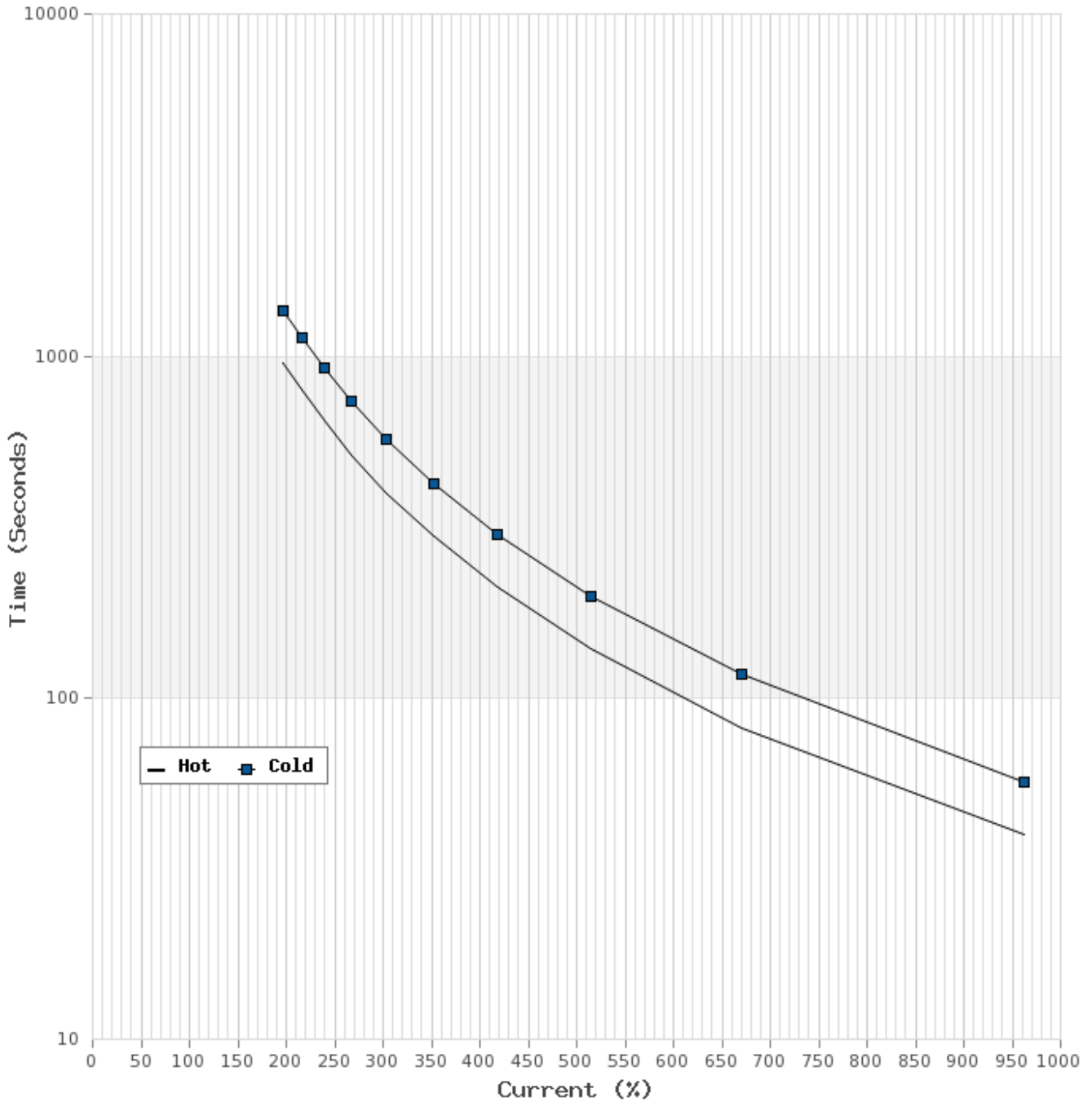

**T-N and I-N Curves**

Motor Type: AEHH8R		Catalogue No: APH1/54		Family: Advantage Plus IEEE Ready	
HP	1.5	Full Load T	4.55 lb-ft	Full Load A	2.1 A
Voltage	460V 60Hz	Locked Rotor T	300 %	Locked Rotor A	20.0 A
RPM	1800	Pull Up T	260 %	Break Down T	360 %

