

Technical Documentation

RD0302
Rolled Steel ODP | ASGH

Date: December 1, 2016

Dimensional Drawing

Catalogue	Model	HP	Pole	kW	Rating	Voltage	Hz	RPM
RD0302	ASGH	30	2	22	Continuous	230 / 460 V	60	3600

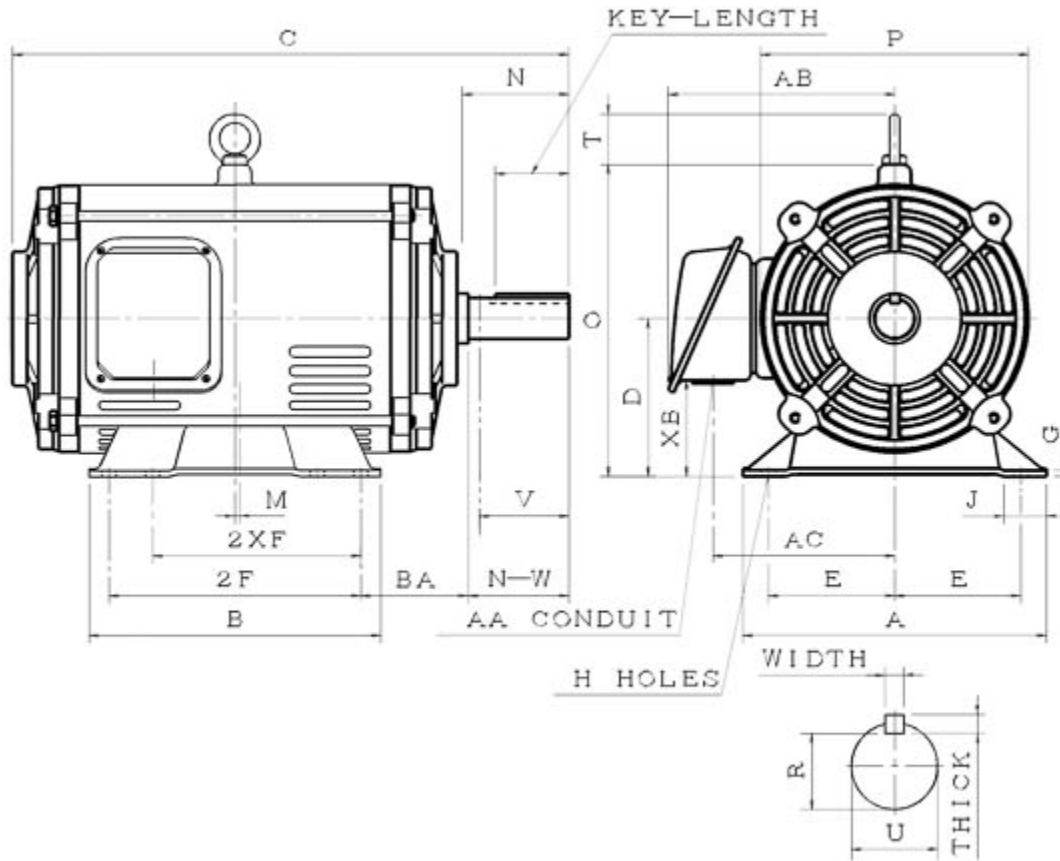

ASGH-SMP-5

Frame Size	Mounting					A	B	C	CD	D	
	E	2F	2F2	H	BA						
284TS	11		9.5	0.53	4.75	12.76	12.76	24.02		7	
G	J	K	L	M	O	P	T	Key			Keyseat
0.24	1.65			0.35	14.28	12.4	2.36	Width	Thick	Length	R
								0.375	0.375	1.93	1.416
Terminal Housing				Aux Box		C/D Flange					
AA	AB	AC	XB	AE	AX	BB	AH	AK	BD	AJ	BF
2.05	10.43	8.27	4.2								
Shaft Extension			Bearings		Approx. Weight Lbs	SPL dBA/3ft	Ins. Class	S.F.	Drive Method	Dimensions	
N-W	U	V	DE	NDE							
3.25	1.625	3.2	6311ZZC3	6211ZZC3	273	75	F	1.15	Direct Coupling	Inches	

Technical Data Sheet

Motor Type: ASGH

Catalogue No: RD0302

Nameplate Information

HP	Pole	RPM	Frame	Voltage	Hz	Phase
30	2	3540	284TS	230 / 460	60	3
Enclosure	Ins. Class	Service Factor	Time Rating	NEMA Design	Rated Amb.	Rated Altitude
ODP	F	1.15	Continuous	B	-40 to 40 °C	<3300 ft

Typical Performance

Efficiency (%)				Power Factor (%)		
Full Load		3/4 Load	1/2 Load	Full Load	3/4 Load	1/2 Load
Nom.	Min.					
92.4	91.0	93.0	93.0	90.0	88.0	83.0
Torque				Current (A)		
Full Load (lb-ft)	Locked Rotor (% FLT)	Pull Up (% FLT)	Break Down (% FLT)	No Load	Full Load	Locked Rotor
44.50	180	135	220	16.0 / 8.0	67.6 / 33.8	435 / 15
NEMA KVA Code	Inertia (WR ²)			Safe Stall Time (s)		Noise Level Sound Press. dB(A)
	Rotor (lb-ft ²)	NEMA Load (lb-ft ²)	Max. Allowable (lb-ft ²)	Cold	Hot	
G	1.588	31	54	17	12	75

VFD Duty Information

Speed Range			VFD		S.F.
Constant Torque	Variable Torque	Constant Power	Carrier	Type	
6-60Hz	3-60Hz	60-120Hz	≤ 5 kHz	VPWM or CPWM	1.0 Only

Additional Information

Bearings		Approx. Weight
DE	NDE	lbs
6311ZZC3	6211ZZC3	273

Hazardous Locations Information

N/A	
Temp Code (Sinewave / VFD)	/

Connection Diagram



12 LEAD DUAL VOLTAGE WYE/DELTA						
VOLTAGE	CONNECTION		L1	L2	L3	JOIN
HIGH	START	WYE	1	2	3	4&7,5&8,6&9 10&11&12
	RUN	DELTA	1,12	2,10	3,11	4&7,5&8,6&9
LOW	START	2 WYE	1,7	2,8	3,9	4&5&6 10&11&12
	RUN	2 DELTA	1,6,7 12	2,4,8 10	3,5,9 11	

WD_12YD

Thermal Limit Curves

Motor Type: ASGH		Catalogue No: RD0302		Family: Rolled Steel ODP	
HP	30	Safe Stall Time		Full Load A	67.6 / 33.8 A
Voltage	230 / 460V 60Hz	Hot	12 s	Locked Rotor A	644 / 44 %
RPM	3600	Cold	17 s	Locked Rotor A	435.0 / 15 A

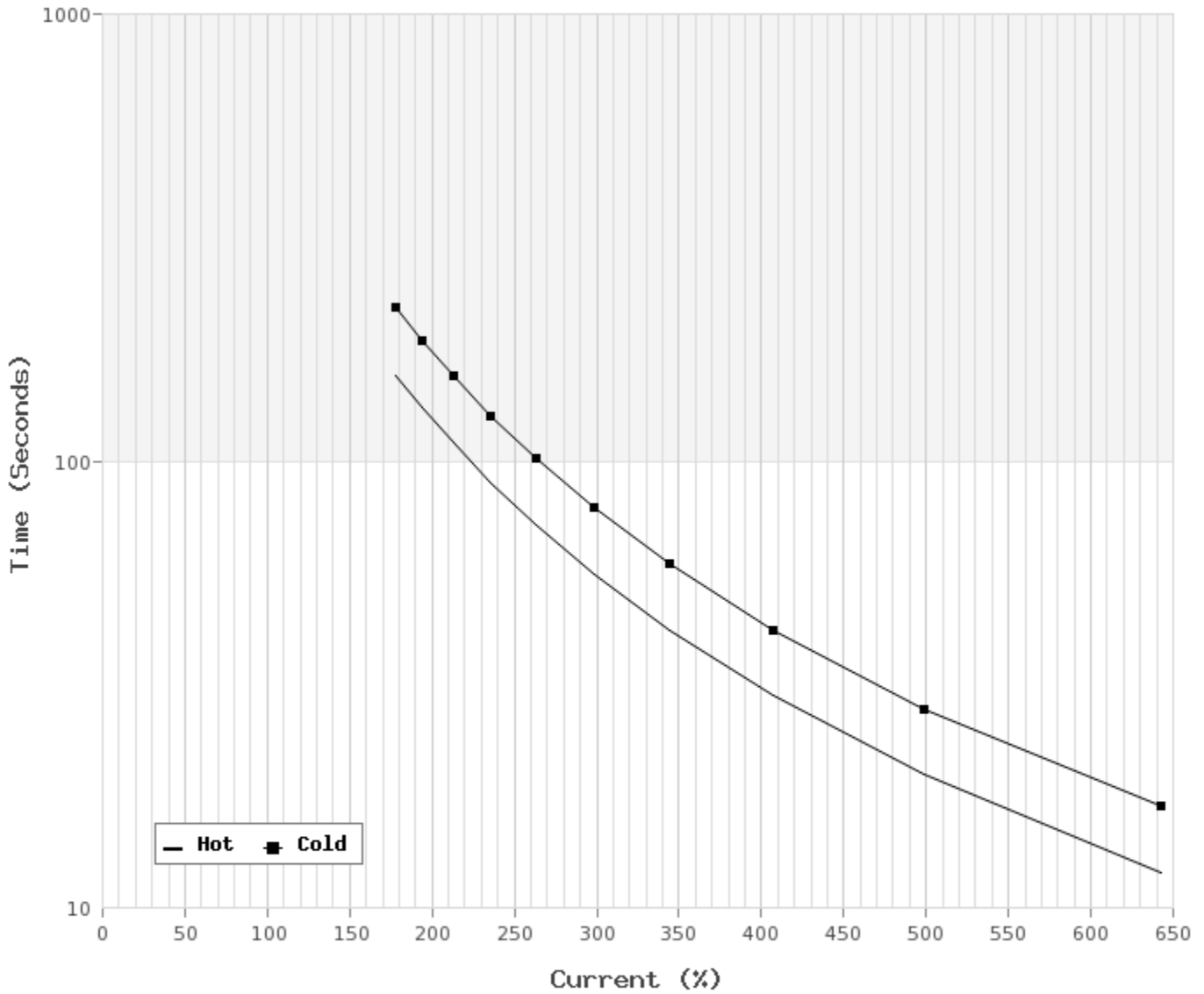

T-N and I-N Curves

Motor Type: ASGH		Catalogue No: RD0302		Family: Rolled Steel ODP	
HP	30	Full Load T	44.50 lb-ft	Full Load A	67.6 / 33.8 A
Voltage	230 / 460V 60Hz	Locked Rotor T	180 %	Locked Rotor A	435.0 / 15.0 A
RPM	3600	Pull Up T	135 %	Break Down T	220 %

