

Technical Documentation

**APH10025-841**  
**Advantage Plus IEEE 841 | AEHH8B**

Date: June 29, 2020

**Dimensional Drawing**

Catalogue	Model	HP	Pole	kW	Rating	Voltage	Hz	RPM
APH10025-841	AEHH8B	100	2	75	Continuous	575	60	3600

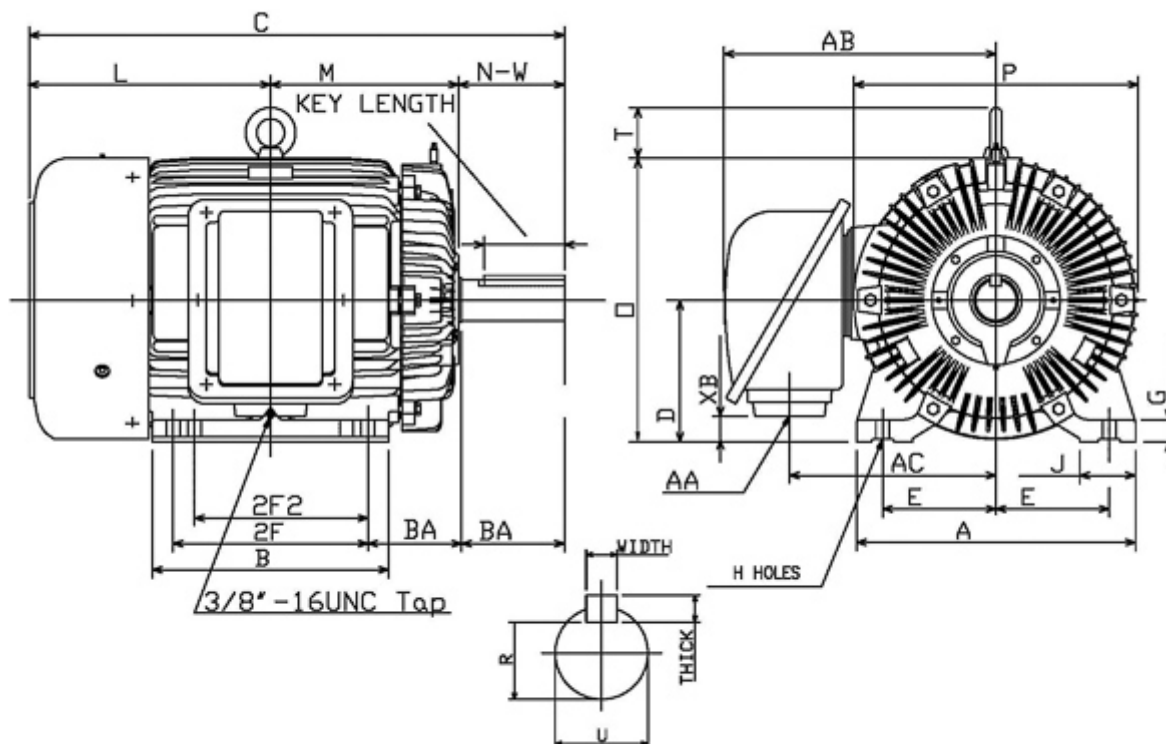

Frame Size	Mounting					A	B	C	CD	D	
	E	2F	2F2	H	BA						
405TS	8	13.75	12.25	0.81	6.62	19.68	16.73	34.99		10	
G	J	K	L	M	O	P	T	Key			Keyseat
1.57	3.94		17.24	13.27	20	20.08	3.54	Width	Thick	Length	R
								0.5	0.5	2.78	1.845
Terminal Housing			Aux Box			C/D Flange					
AA	AB	AC	XB	AE	AX	BB	AH	AK	BD	AJ	BF
NPT3"	19.41	14.76	1.81								
Shaft Extension			Bearings		Approx. Weight Lbs	SPL dBA/3ft	Ins. Class	S.F.	Drive Method	Dimensions	
N-W	U	V	DE	NDE							
4.25	2.125	4.13	6313C3	6313ZC3	1225	83	F	1.15	Direct Coupling	Inches	

	
	Date: June 29, 2020

### Technical Data Sheet

Motor Type: AEHH8B	Catalogue No: APH10025-841
--------------------	----------------------------

#### Nameplate Information

HP	Pole	RPM	Frame	Voltage	Hz	Phase
100	2	3560	405TS	575	60	3
Enclosure	Ins. Class	Service Factor	Time Rating	NEMA Design	Rated Amb.	Rated Altitude
TEFC	F	1.15	Continuous	B	-40 to 40 °C	<1000 m

#### Typical Performance

Efficiency (%)				Power Factor (%)		
Full Load		3/4 Load	1/2 Load	Full Load	3/4 Load	1/2 Load
Nom.	Min.					
95.4	94.5	95.8	95.4	92.0	91.5	88.5
Torque				Current (A)		
Full Load (lb-ft)	Locked Rotor (% FLT)	Pull Up (% FLT)	Break Down (% FLT)	No Load	Full Load	Locked Rotor
147.50	140	125	270	15.7	85.4	580
NEMA KVA Code	Inertia (WR <sup>2</sup> )			Safe Stall Time (s)		Noise Level Sound Press. dB(A)
	Rotor (lb-ft <sup>2</sup> )	NEMA Load (lb-ft <sup>2</sup> )	Max. Allowable (lb-ft <sup>2</sup> )	Cold	Hot	
G	10.773	92.00	213.00	17	12	83

#### VFD Duty Information

Speed Range			VFD		S.F.
Constant Torque	Variable Torque	Constant Power	Carrier	Type	
6-60Hz	3-60Hz	60-60Hz	≤ 5 kHz	VPWM or CPWM	1.0 Only

#### Hazardous Locations Information

CSA Certified	
Class I, Div 2, Groups B, C & D Class I, Zone 2, Groups IIB+H2, IIB & IIA	
Temp Code (Sinewave / VFD)	T3C / T3

#### Additional Certifications

Other Certification
---------------------

#### Additional Information

Bearings		Approx. Weight
DE	NDE	lbs
6313C3	6313ZC3	1225

**Nameplate Drawing**

# Advantage Plus IEEE 841

TYPE	AEHH8B	CAT. NO.	APH10025-841		
OUTPUT	100 HP 75 kW	FRAME	405TS	TEFC	
R.P.M.	3560	POLE	2	INS.	F
VOLTS	575	PHASE	3	Hz	60
AMPS	85.4	CODE	G	S.F.	1.15
AMBIENT	40 °C	NOM. EFF. 95.4		MIN. EFF. 94.5	
BEARINGS	6313C3 / 6313ZC3			RATING Cont.	
SER. NO.	TBD	DESIGN	B	WT. 1225 LBS	
PWM VFD DUTY	VT	CT	CP	S.F.	
	3-60Hz	6-60Hz	60-60Hz	1.0 Only	

**Connection Diagram**



3 LEAD		SINGLE VOLTAGE			DELTA
VOLTAGE	CONN.	L1	L2	L3	
-	DELTA	1	2	3	

WD\_3D

**Thermal Limit Curves**

Motor Type: AEHH8B		Catalogue No: APH10025-841		Family: Advantage Plus IEEE 841	
HP	100	Safe Stall Time		Full Load A	85.4 A
Voltage	575V 60Hz	Hot	12 s	% Inrush	680 %
RPM	3600	Cold	17 s	Locked Rotor A	580 A

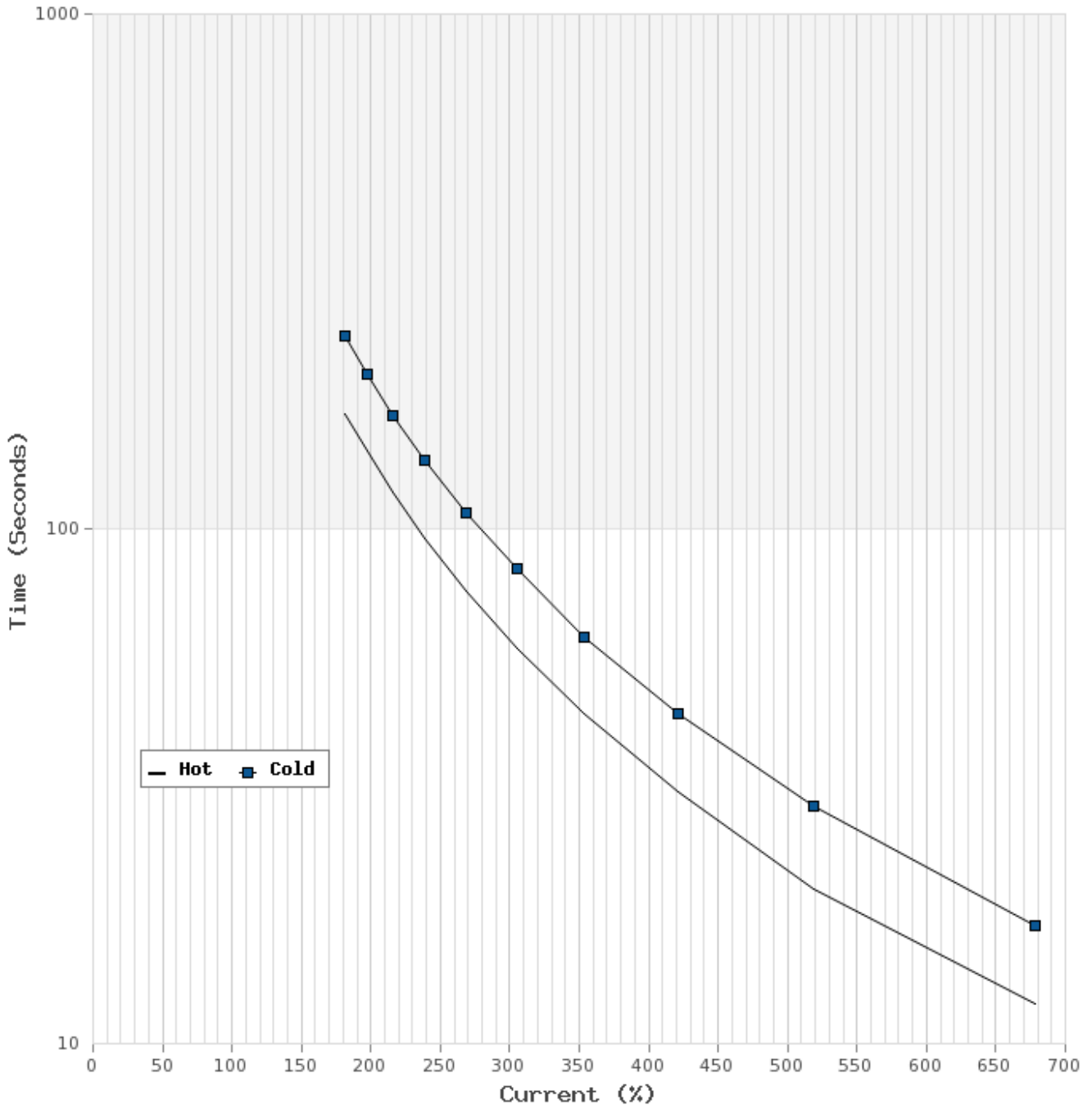

**T-N and I-N Curves**

Motor Type: AEHH8B		Catalogue No: APH10025-841		Family: Advantage Plus IEEE 841	
HP	100	Full Load T	147.50 lb-ft	Full Load A	85.4 A
Voltage	575V 60Hz	Locked Rotor T	140 %	Locked Rotor A	580.0 A
RPM	3600	Pull Up T	125 %	Break Down T	270 %

