

Technical Documentation

APH0108-841
Advantage Plus IEEE 841 | AEHH8B

Date: June 26, 2020

Dimensional Drawing

Catalogue	Model	HP	Pole	kW	Rating	Voltage	Hz	RPM
APH0108-841	AEHH8B	10	8	7.5	Continuous	460	60	900

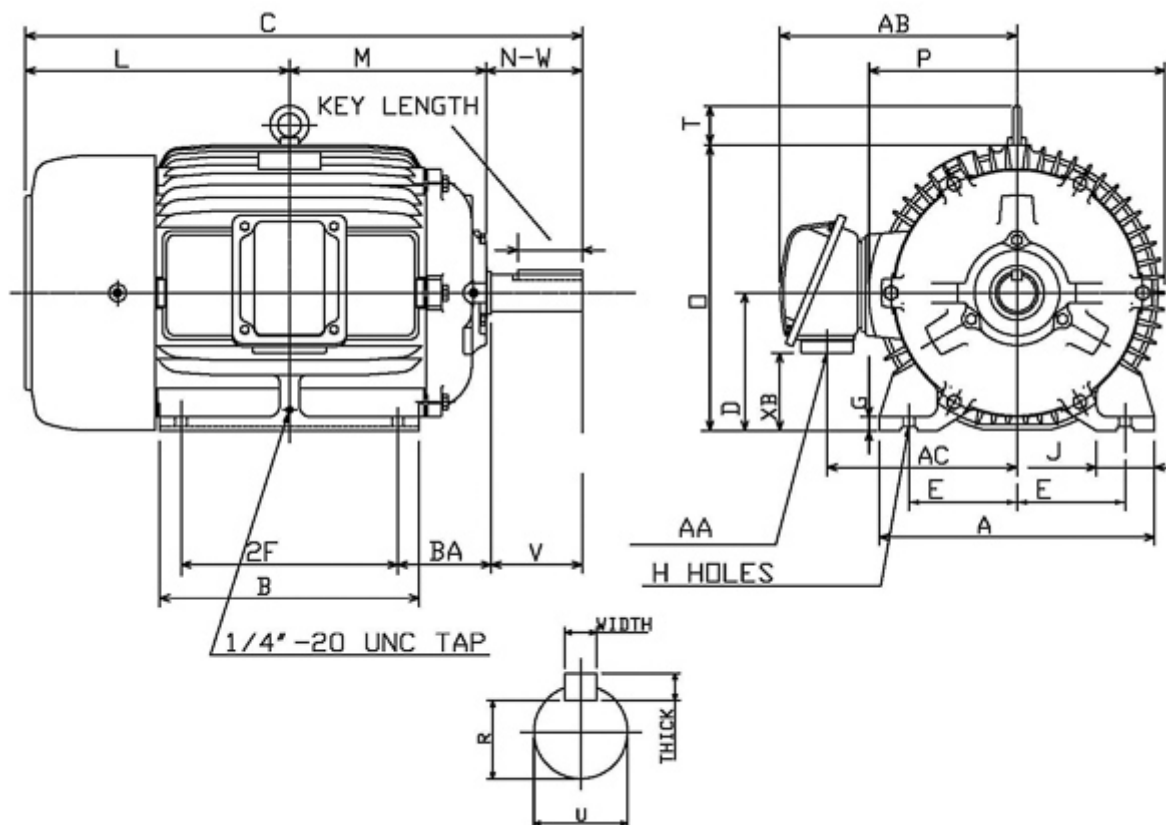

Frame Size	Mounting					A	B	C	CD	D	
	E	2F	2F2	H	BA						
284T	5.5	9.5		0.53	4.75	13.98	11.69	26.8		7	
G	J	K	L	M	O	P	T	Key			Keyseat
0.7	2.95		12.68	9.23	14.5	15.05	2.36	Width	Thick	Length	R
								0.5	0.5	3.28	1.591
Terminal Housing				Aux Box		C/D Flange					
AA	AB	AC	XB	AE	AX	BB	AH	AK	BD	AJ	BF
NPT11/2"	13.27	10.35	3.54								
Shaft Extension			Bearings		Approx. Weight Lbs	SPL dBA/3ft	Ins. Class	S.F.	Drive Method	Dimensions	
N-W	U	V	DE	NDE							
4.62	1.875	4.5	6311ZC3	6310ZC3	407	59	F	1.15	Direct Coupling / Belt Drive	Inches	

	
	Date: June 26, 2020

Technical Data Sheet

Motor Type: AEHH8B	Catalogue No: APH0108-841
--------------------	---------------------------

Nameplate Information

HP	Pole	RPM	Frame	Voltage	Hz	Phase
10	8	885	284T	460	60	3
Enclosure	Ins. Class	Service Factor	Time Rating	NEMA Design	Rated Amb.	Rated Altitude
TEFC	F	1.15	Continuous	B	-40 to 40 °C	<1000 m

Typical Performance

Efficiency (%)				Power Factor (%)		
Full Load		3/4 Load	1/2 Load	Full Load	3/4 Load	1/2 Load
Nom.	Min.					
89.5	87.5	89.5	87.5	73.5	66.0	53.5
Torque				Current (A)		
Full Load (lb-ft)	Locked Rotor (% FLT)	Pull Up (% FLT)	Break Down (% FLT)	No Load	Full Load	Locked Rotor
59.33	235	210	280	8.2	14.2	81
NEMA KVA Code	Inertia (WR ²)			Safe Stall Time (s)		Noise Level Sound Press. dB(A)
	Rotor (lb-ft ²)	NEMA Load (lb-ft ²)	Max. Allowable (lb-ft ²)	Cold	Hot	
H	5.421	273.00	588.00	32	22	59

VFD Duty Information

Speed Range			VFD		S.F.
Constant Torque	Variable Torque	Constant Power	Carrier	Type	
6-60Hz	3-60Hz	60-120Hz	≤ 5 kHz	VPWM or CPWM	1.0 Only

Hazardous Locations Information

CSA Certified
Class I, Div 2, Groups B, C & D Class I, Zone 2, Groups IIB+H2, IIB & IIA
Temp Code (Sinewave / VFD) T3A / T3A

Additional Certifications

Other Certification

Additional Information

Bearings		Approx. Weight
DE	NDE	lbs
6311ZC3	6310ZC3	407

Nameplate Drawing

Advantage Plus IEEE 841

TYPE	AEHH8B	CAT. NO.	APH0108-841		
OUTPUT	10 HP 7.5 kW	FRAME	284T	TEFC	
R.P.M.	885	POLE	8	INS.	F
VOLTS	460	PHASE	3	Hz	60
AMPS	14.2	CODE	H	S.F.	1.15
AMBIENT	40 °C	NOM. EFF. 89.5		MIN. EFF. 87.5	
BEARINGS	6311ZC3 / 6310ZC3			RATING Cont.	
SER. NO.	TBD	DESIGN	B	WT. 407 LBS	
PWM VFD DUTY	VT	CT	CP	S.F.	
	3-60Hz	6-60Hz	60-120Hz	1.0 Only	

Connection Diagram



3 LEAD		SINGLE VOLTAGE			DELTA
VOLTAGE	CONN.	L1	L2	L3	
-	DELTA	1	2	3	

WD_3D

Thermal Limit Curves

Motor Type: AEHH8B		Catalogue No: APH0108-841		Family: Advantage Plus IEEE 841	
HP	10	Safe Stall Time		Full Load A	14.2 A
Voltage	460V 60Hz	Hot	22 s	% Inrush	569 %
RPM	900	Cold	32 s	Locked Rotor A	81 A

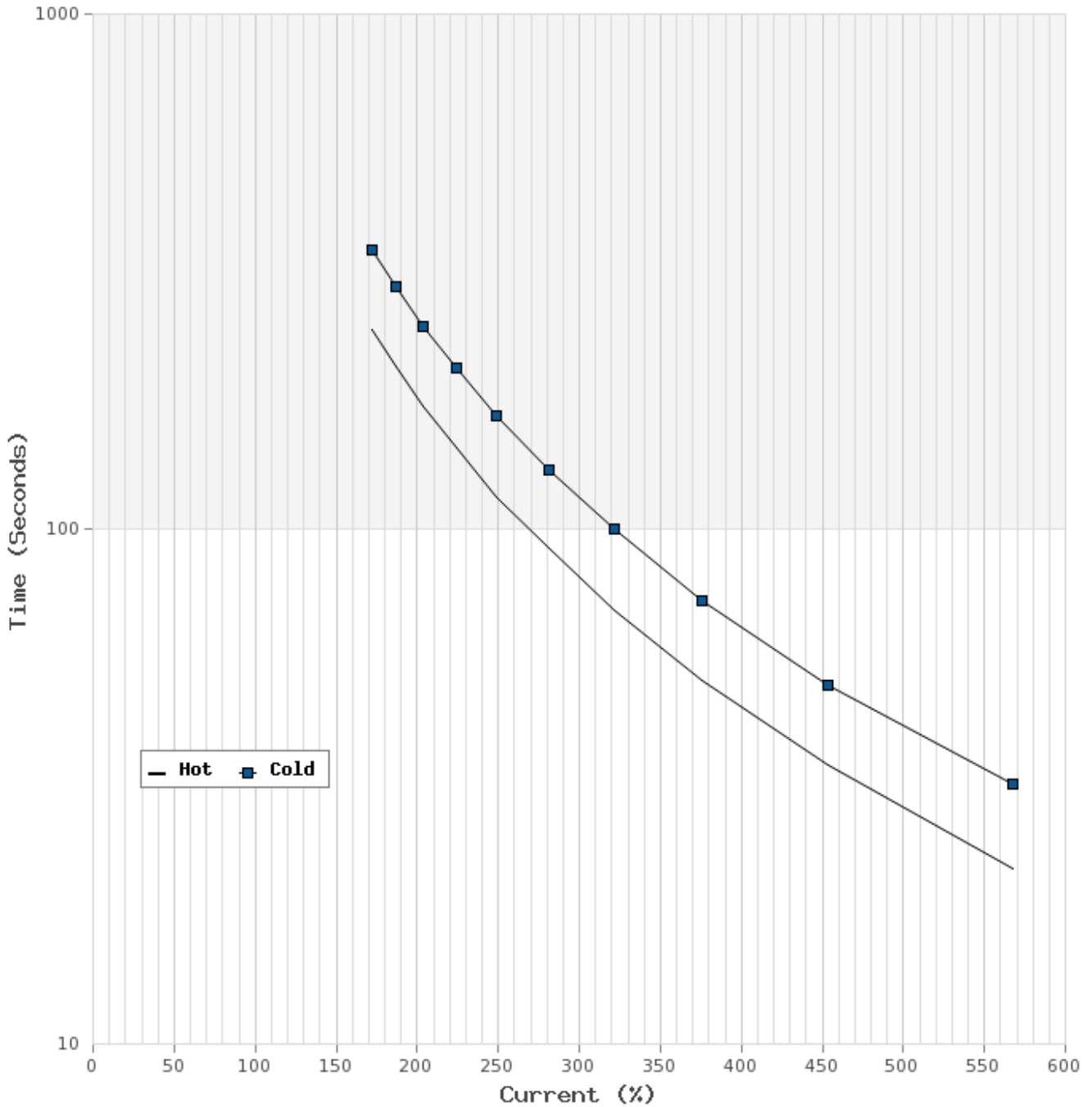

T-N and I-N Curves

Motor Type: AEHH8B		Catalogue No: APH0108-841		Family: Advantage Plus IEEE 841	
HP	10	Full Load T	59.33 lb-ft	Full Load A	14.2 A
Voltage	460V 60Hz	Locked Rotor T	235 %	Locked Rotor A	81.0 A
RPM	900	Pull Up T	210 %	Break Down T	280 %

