

Technical Documentation

**APH45025-841**  
**Advantage Plus IEEE 841 | AEHH8B**

Date: June 30, 2020

### Dimensional Drawing

Catalogue	Model	HP	Pole	kW	Rating	Voltage	Hz	RPM
APH45025-841	AEHH8B	450	2	336	Continuous	575	60	3600

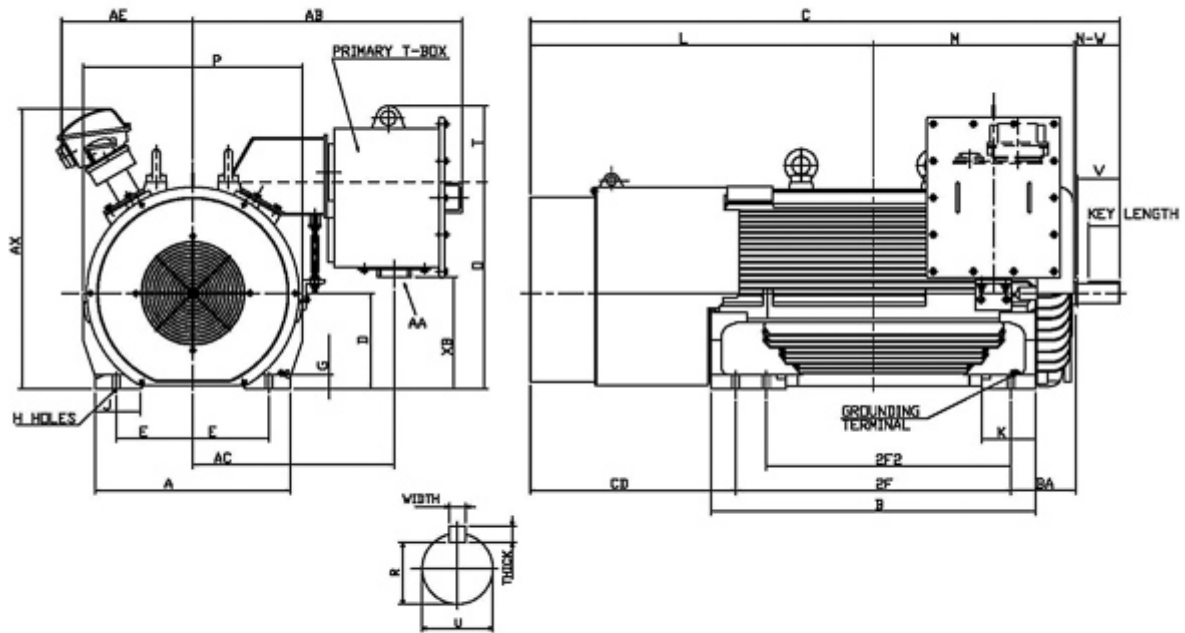

Frame Size	Mounting					A	B	C	CD	D	
	E	2F	2F2	H	BA						
5011A	10	36		0.94	8.5	25.6	42.5	77.15		12.5	
G	J	K	L	M	O	P	T	Key			Keyseat R
								Width	Thick	Length	
1.85	5.9	7.1	44.9	25.8	27.07	28.75	14.7	0.625	0.625	4.01	2.275
Terminal Housing			Aux Box			C/D Flange					
AA	AB	AC	XB	AE	AX	BB	AH	AK	BD	AJ	BF
	36.95	24.8	14.67	17.83	36.67						
Shaft Extension			Bearings		Approx. Weight Lbs	SPL dBA/3ft	Ins. Class	S.F.	Drive Method	Dimensions	
N-W	U	V	DE	NDE							
5.75	2.625	5.5	6315C3	6315C3	4400	83	F	1.15	Direct Coupling	Inches	

	
	Date: June 30, 2020

### Technical Data Sheet

Motor Type: AEHH8B	Catalogue No: APH45025-841
--------------------	----------------------------

#### Nameplate Information

HP	Pole	RPM	Frame	Voltage	Hz	Phase
450	2	3580	5011A	575	60	3
Enclosure	Ins. Class	Service Factor	Time Rating	NEMA Design	Rated Amb.	Rated Altitude
TEFC	F	1.15	Continuous	B	-40 to 40 °C	<1000 m

#### Typical Performance

Efficiency (%)				Power Factor (%)		
Full Load		3/4 Load	1/2 Load	Full Load	3/4 Load	1/2 Load
Nom.	Min.					
95.8	95.0	95.4	94.0	91.7	91.0	87.0
Torque				Current (A)		
Full Load (lb-ft)	Locked Rotor (% FLT)	Pull Up (% FLT)	Break Down (% FLT)	No Load	Full Load	Locked Rotor
659.30	80	80	230	58.8	383.7	2600
NEMA KVA Code	Inertia (WR <sup>2</sup> )			Safe Stall Time (s)		Noise Level Sound Press. dB(A)
	Rotor (lb-ft <sup>2</sup> )	NEMA Load (lb-ft <sup>2</sup> )	Max. Allowable (lb-ft <sup>2</sup> )	Cold	Hot	
G	75.600	349.00	349.00	36	28	83

#### VFD Duty Information

Speed Range			VFD		S.F.
Constant Torque	Variable Torque	Constant Power	Carrier	Type	
20-60Hz	3-60Hz	60-60Hz	≤ 5 kHz	VPWM or CPWM	1.0 Only

#### Hazardous Locations Information

CSA Certified
Class I, Div 2, Groups B, C & D Class I, Zone 2, Groups IIB+H2, IIB & IIA
Temp Code (Sinewave / VFD)
T3 / T3

#### Additional Certifications

Other Certification
---------------------

#### Additional Information

Bearings		Approx. Weight
DE	NDE	lbs
6315C3	6315C3	4400

**Nameplate Drawing**

# Advantage Plus IEEE 841

TYPE	AEHH8B	CAT. NO.	APH45025-841		
OUTPUT	450 HP 336 kW	FRAME	5011A	TEFC	
R.P.M.	3580	POLE	2	INS.	F
VOLTS	575	PHASE	3	Hz	60
AMPS	383.7	CODE	G	S.F.	1.15
AMBIENT	40 °C	NOM. EFF. 95.8		MIN. EFF. 95.0	
BEARINGS	6315C3 / 6315C3			RATING Cont.	
SER. NO.	TBD	DESIGN	B	WT. 4400 LBS	
PWM VFD DUTY	VT	CT	CP	S.F.	
	3-60Hz	20-60Hz	60-60Hz	1.0 Only	

**Connection Diagram**

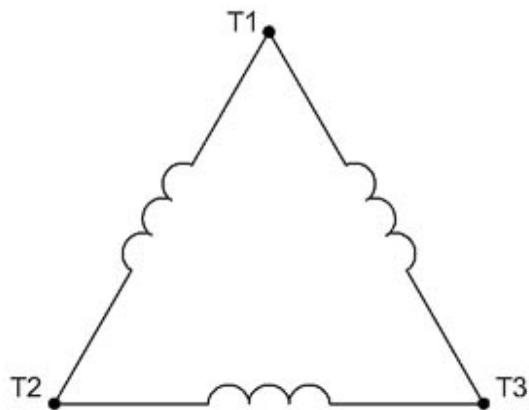

3 LEAD		SINGLE VOLTAGE			DELTA
VOLTAGE	CONN.	L1	L2	L3	
-	DELTA	1	2	3	

WD\_3D

### Thermal Limit Curves

Motor Type: AEHH8B		Catalogue No: APH45025-841		Family: Advantage Plus IEEE 841	
HP	450	Safe Stall Time		Full Load A	383.7 A
Voltage	575V 60Hz	Hot	28 s	% Inrush	678 %
RPM	3600	Cold	36 s	Locked Rotor A	2600 A

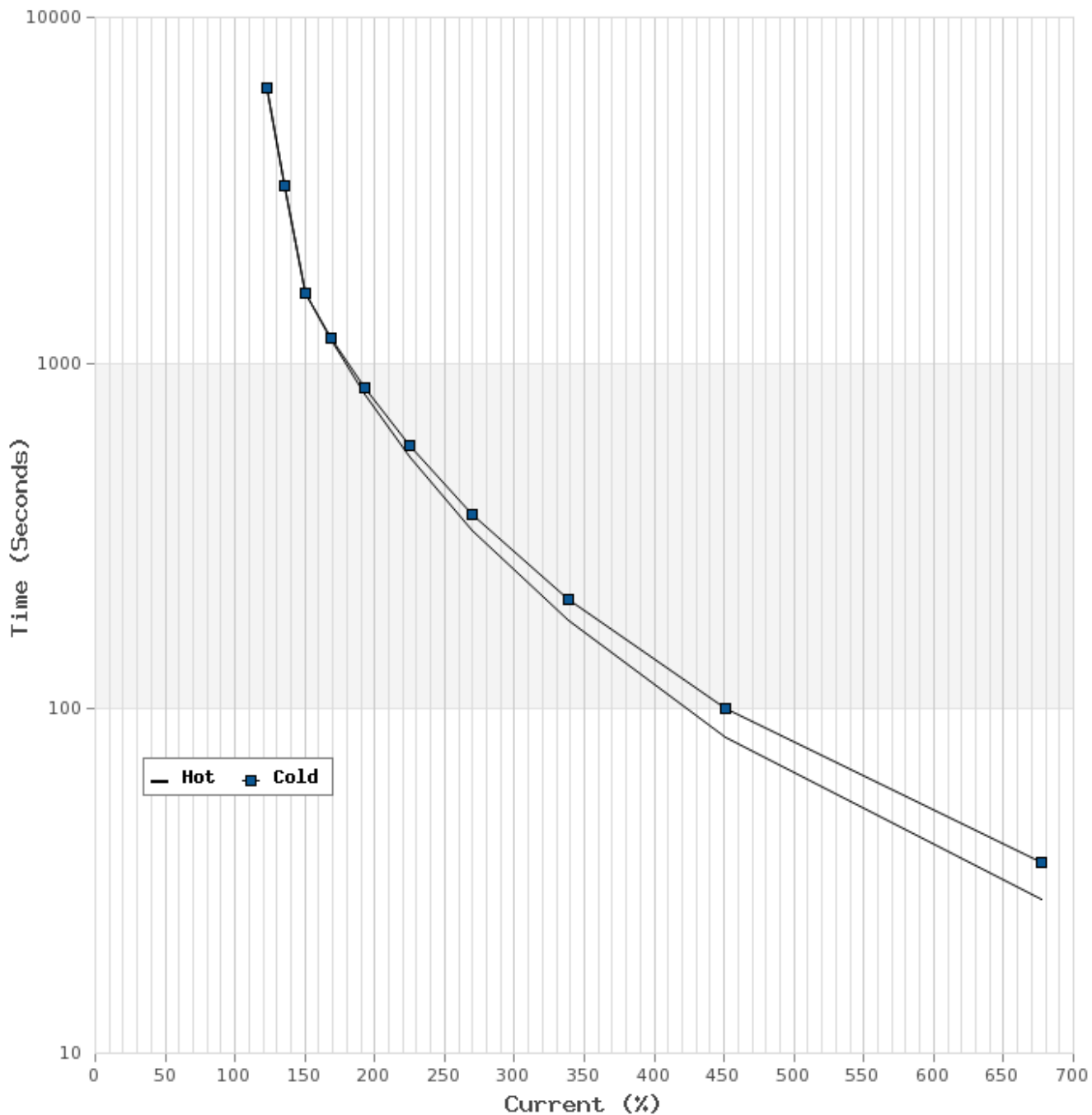

**T-N and I-N Curves**

Motor Type: AEHH8B		Catalogue No: APH45025-841		Family: Advantage Plus IEEE 841	
HP	450	Full Load T	659.30 lb-ft	Full Load A	383.7 A
Voltage	575V 60Hz	Locked Rotor T	80 %	Locked Rotor A	2600.0 A
RPM	3600	Pull Up T	80 %	Break Down T	230 %

