

Technical Documentation

**APH12585-841**  
**Advantage Plus IEEE 841 | AEHH8B**

Date: June 29, 2020

**Dimensional Drawing**

Catalogue	Model	HP	Pole	kW	Rating	Voltage	Hz	RPM
APH12585-841	AEHH8B	125	8	93	Continuous	575	60	900

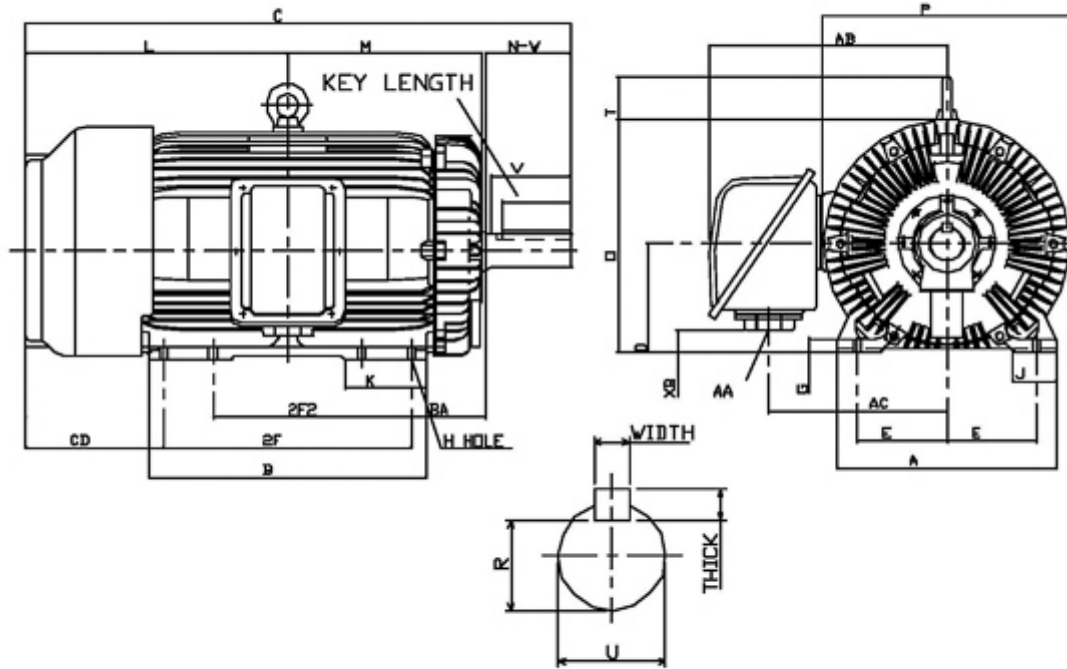

Frame Size	Mounting					A	B	C	CD	D	
	E	2F	2F2	H	BA						
447T	9	20	16.5	0.81	7.5	22.05	23.25	49.9	13.9	11	
G	J	K	L	M	O	P	T	Key			Keyseat
1.4	4.35	6.7	23.9	17.15	23.55	24.75	7.33	Width	Thick	Length	R
								0.875	0.875	6.91	2.88
Terminal Housing			Aux Box			C/D Flange					
AA	AB	AC	XB	AE	AX	BB	AH	AK	BD	AJ	BF
NPT3"	24	17.9	2.4								
Shaft Extension			Bearings		Approx. Weight Lbs	SPL dBA/3ft	Ins. Class	S.F.	Drive Method	Dimensions	
N-W	U	V	DE	NDE							
8.5	3.375	8	6320C3	6316C3	2068	78	F	1.15	Direct Coupling / Belt Drive	Inches	

	
	Date: June 29, 2020

### Technical Data Sheet

Motor Type: AEHH8B	Catalogue No: APH12585-841
--------------------	----------------------------

#### Nameplate Information

HP	Pole	RPM	Frame	Voltage	Hz	Phase
125	8	888	447T	575	60	3
Enclosure	Ins. Class	Service Factor	Time Rating	NEMA Design	Rated Amb.	Rated Altitude
TEFC	F	1.15	Continuous	B	-40 to 40 °C	<1000 m

#### Typical Performance

Efficiency (%)				Power Factor (%)		
Full Load		3/4 Load	1/2 Load	Full Load	3/4 Load	1/2 Load
Nom.	Min.					
93.6	92.4	93.0	91.7	80.0	77.0	69.0
Torque				Current (A)		
Full Load (lb-ft)	Locked Rotor (% FLT)	Pull Up (% FLT)	Break Down (% FLT)	No Load	Full Load	Locked Rotor
739.00	150	125	200	40.1	125.1	726
NEMA KVA Code	Inertia (WR <sup>2</sup> )			Safe Stall Time (s)		Noise Level Sound Press. dB(A)
	Rotor (lb-ft <sup>2</sup> )	NEMA Load (lb-ft <sup>2</sup> )	Max. Allowable (lb-ft <sup>2</sup> )	Cold	Hot	
G	141.000	2919.00	5838.00	23	17	78

#### VFD Duty Information

Speed Range			VFD		S.F.
Constant Torque	Variable Torque	Constant Power	Carrier	Type	
12-60Hz	3-60Hz	60-90Hz	≤ 5 kHz	VPWM or CPWM	1.0 Only

#### Hazardous Locations Information

CSA Certified
Class I, Div 2, Groups B, C & D Class I, Zone 2, Groups IIB+H2, IIB & IIA
Temp Code (Sinewave / VFD)      T3 / T3

#### Additional Certifications

Other Certification
---------------------

#### Additional Information

Bearings		Approx. Weight
DE	NDE	lbs
6320C3	6316C3	2068

**Nameplate Drawing**

# Advantage Plus IEEE 841

TYPE	AEHH8B	CAT. NO.	APH12585-841		
OUTPUT	125 HP 93 kW	FRAME	447T	TEFC	
R.P.M.	888	POLE	8	INS.	F
VOLTS	575	PHASE	3	Hz	60
AMPS	125.1	CODE	G	S.F.	1.15
AMBIENT	40 °C	NOM. EFF. 93.6		MIN. EFF. 92.4	
BEARINGS	6320C3 / 6316C3			RATING Cont.	
SER. NO.	TBD	DESIGN	B	WT. 2068 LBS	
PWM VFD DUTY	VT	CT	CP	S.F.	
	3-60Hz	12-60Hz	60-90Hz	1.0 Only	

**Connection Diagram**



3 LEAD		SINGLE VOLTAGE			DELTA
VOLTAGE	CONN.	L1	L2	L3	
-	DELTA	1	2	3	

WD\_3D

### Thermal Limit Curves

Motor Type: AEHH8B		Catalogue No: APH12585-841		Family: Advantage Plus IEEE 841	
HP	125	Safe Stall Time		Full Load A	125.1 A
Voltage	575V 60Hz	Hot	17 s	% Inrush	581 %
RPM	900	Cold	23 s	Locked Rotor A	726 A

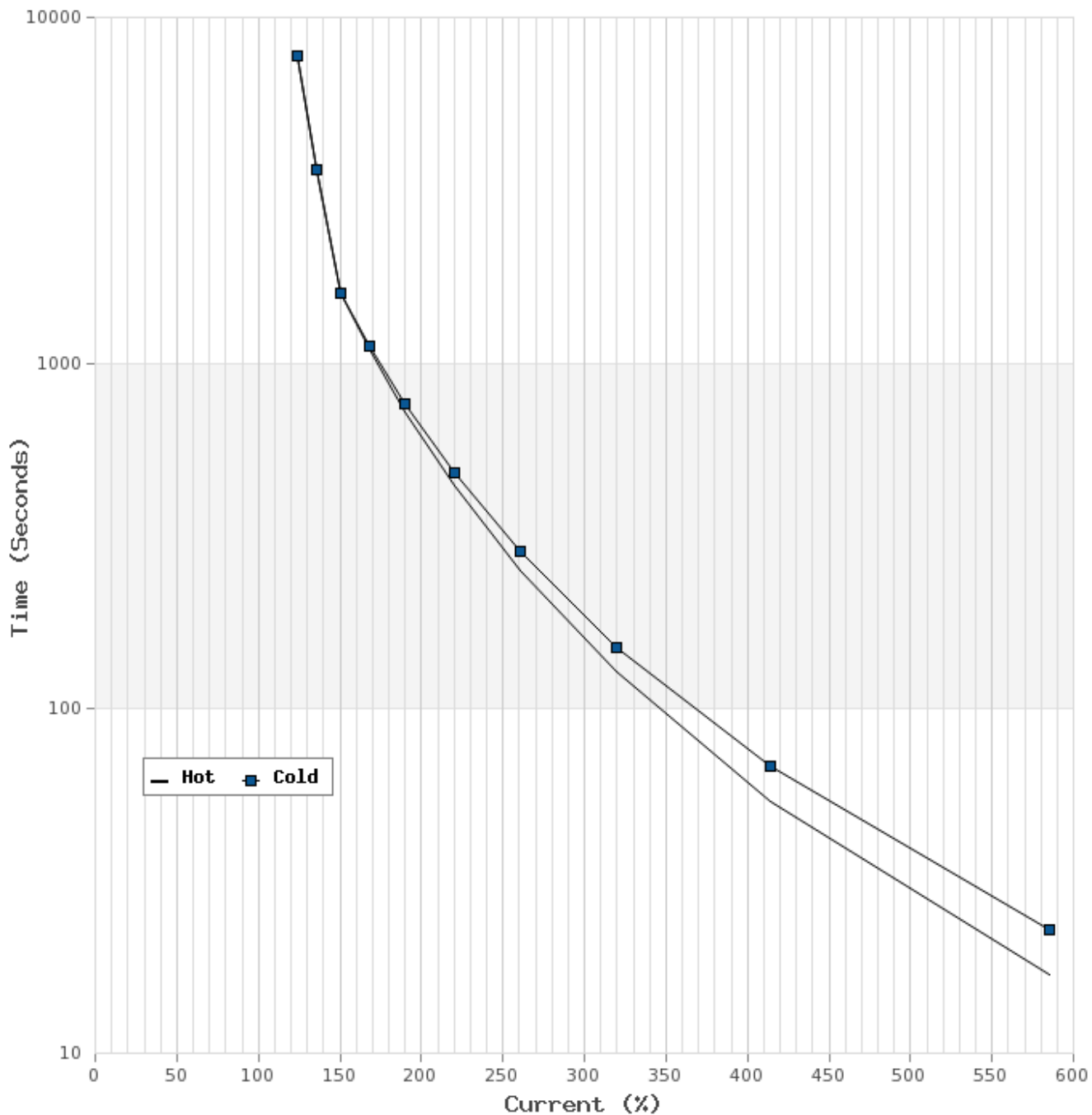

**T-N and I-N Curves**

Motor Type: AEHH8B		Catalogue No: APH12585-841		Family: Advantage Plus IEEE 841	
HP	125	Full Load T	739.00 lb-ft	Full Load A	125.1 A
Voltage	575V 60Hz	Locked Rotor T	150 %	Locked Rotor A	726.0 A
RPM	900	Pull Up T	125 %	Break Down T	200 %

