

Technical Documentation

# **CJM0054**

## **Optim JM | AEHH8N\_JM**

Date: November 29, 2016

**Dimensional Drawing**

Catalogue	Model	HP	Pole	kW	Rating	Voltage	Hz	RPM
CJM0054	AEHH8N_JM	5	4	3.7	Continuous	230 / 460 V	60	1800

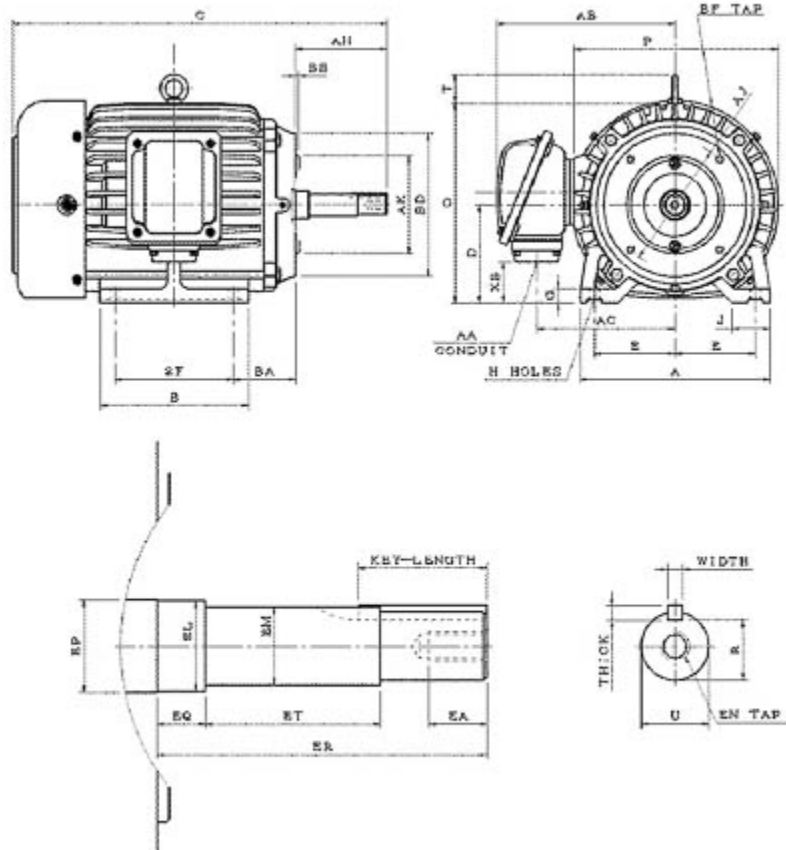

AEHH8N-JM-SMP-2

Frame Size	Mounting					A	B	C	CD	D	
	E	2F	2F2	H	BA						
184JM	3.75	5.5		0.41	2.88	8.82	6.89	17.54		4.5	
G	J	K	L	M	O	P	T	Key			Keyseat
0.65	1.75				9.31	9.61	1.3	Width	Thick	Length	R
								0.188	0.188	1.65	0.771
Terminal Housing			Aux Box			C/D Flange					
AA	AB	AC	XB	AE	AX	BB	AH	AK	BD	AJ	BF
3/4"	8.31	6.38	1.86			0.156	4.25	4.5	6.61	5.875	4-3/8"-16UNC
Shaft Extension			Bearings		Approx. Weight Lbs	SPL dBA/3ft	Ins. Class	S.F.	Drive Method	Dimensions	
N-W	U	V	DE	NDE							
	0.875		6306ZZ	6306ZZ	110	54	F	1.15	DirectCoupling	Inches	

### Technical Data Sheet

Motor Type: AEHH8N\_JM

Catalogue No: CJM0054

#### Nameplate Information

HP	Pole	RPM	Frame	Voltage	Hz	Phase
5	4	1745	184JM	230 / 460	60	3
Enclosure	Ins. Class	Service Factor	Time Rating	NEMA Design	Rated Amb.	Rated Altitude
TEFC	F	1.15	Continuous	B	-40 to 40 °C	<3300 ft

#### Typical Performance

Efficiency (%)				Power Factor (%)		
Full Load		3/4 Load	1/2 Load	Full Load	3/4 Load	1/2 Load
Nom.	Min.					
89.5	87.5	88.5	88.5	85.5	81.5	71.5
Torque				Current (A)		
Full Load (lb-ft)	Locked Rotor (% FLT)	Pull Up (% FLT)	Break Down (% FLT)	No Load	Full Load	Locked Rotor
15.04	185	140	285	4.4 / 2.2	12.2 / 6.1	92 / 46
NEMA KVA Code	Inertia (WR <sup>2</sup> )			Safe Stall Time (s)		Noise Level Sound Press. dB(A)
	Rotor (lb-ft <sup>2</sup> )	NEMA Load (lb-ft <sup>2</sup> )	Max. Allowable (lb-ft <sup>2</sup> )	Cold	Hot	
J	0.422	27	88	35	25	54

#### VFD Duty Information

Speed Range			VFD		S.F.
Constant Torque	Variable Torque	Constant Power	Carrier	Type	
6-60Hz	3-60Hz	60-120Hz	≤ 5 kHz	VPWM or CPWM	1.0 Only

#### Additional Information

Bearings		Approx. Weight
DE	NDE	lbs
6306ZZ	6306ZZ	110

#### Hazardous Locations Information

CSA Certified	
Class I, Div 2, Groups B, C & D	
Class I, Zone 2, Groups IIB+H2, IIB & IIA	
Temp Code (Sinewave / VFD)	T3C / T3C

**Connection Diagram**



9 LEAD DUAL VOLTAGE WYE					
VOLTAGE	CONN.	L1	L2	L3	JOIN
HIGH	WYE	1	2	3	4&7,5&8,6&9
LOW	2 WYE	1,7	2,8	3,9	4&5&6

WD\_9Y

**Thermal Limit Curves**

Motor Type: AEHH8N_JM		Catalogue No: CJM0054		Family: Optim JM	
HP	5	Safe Stall Time		Full Load A	12.2 / 6.1 A
Voltage	230 / 460V 60Hz	Hot	25 s	Locked Rotor A	752 / 752 %
RPM	1800	Cold	35 s	Locked Rotor A	92.0 / 46 A

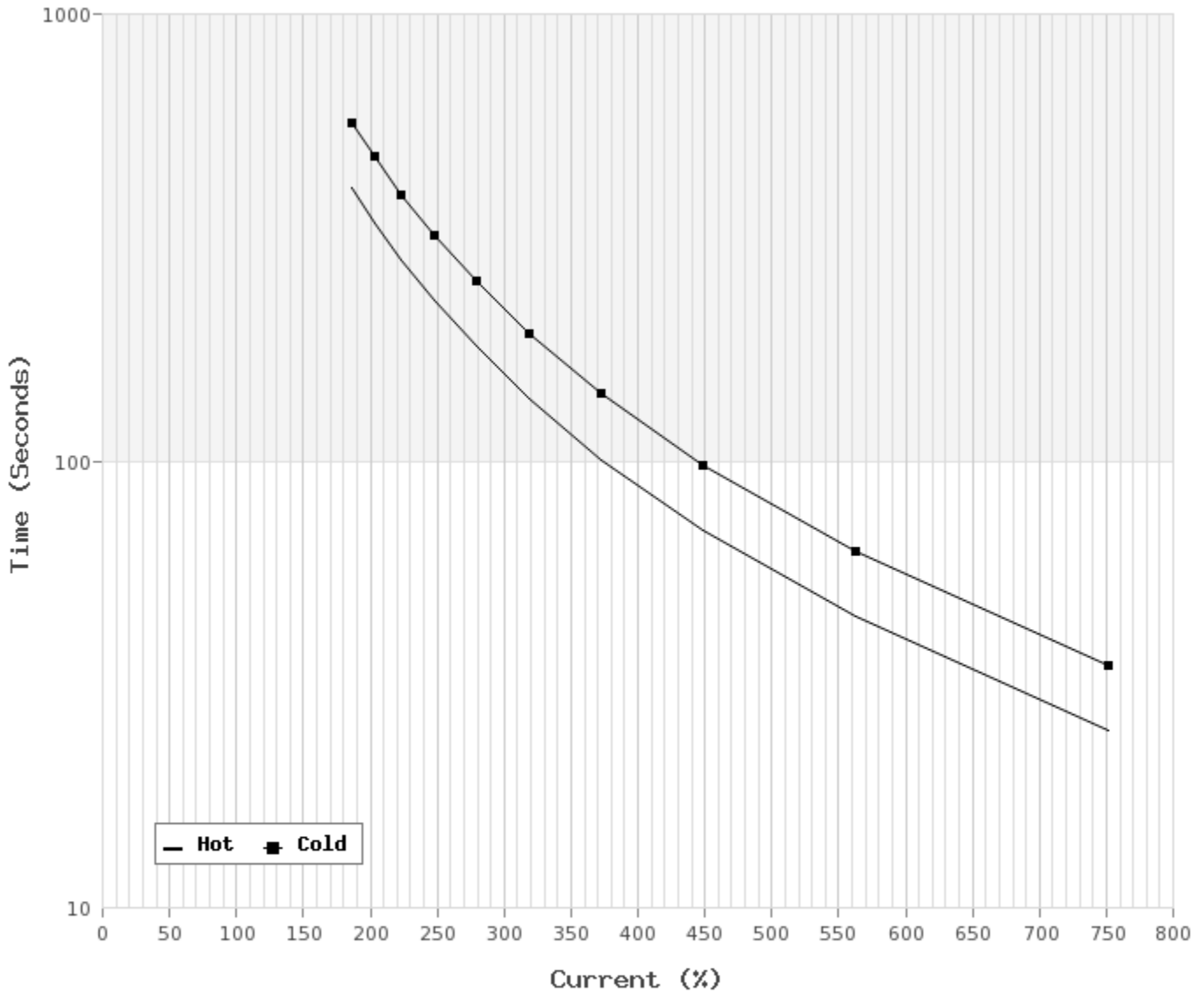

**T-N and I-N Curves**

Motor Type: AEHH8N_JM		Catalogue No: CJM0054		Family: Optim JM	
HP	5	Full Load T	15.04 lb-ft	Full Load A	12.2 / 6.1 A
Voltage	230 / 460V 60Hz	Locked Rotor T	185 %	Locked Rotor A	92.0 / 46.0 A
RPM	1800	Pull Up T	140 %	Break Down T	285 %

