

Technical Documentation

XC00285
Optim TEXP | AEHHXV

Date: December 1, 2016

Dimensional Drawing

Catalogue	Model	HP	Pole	kW	Rating	Voltage	Hz	RPM
XC00285	AEHHXV	2	8	1.5	Continuous	575 V	60	900

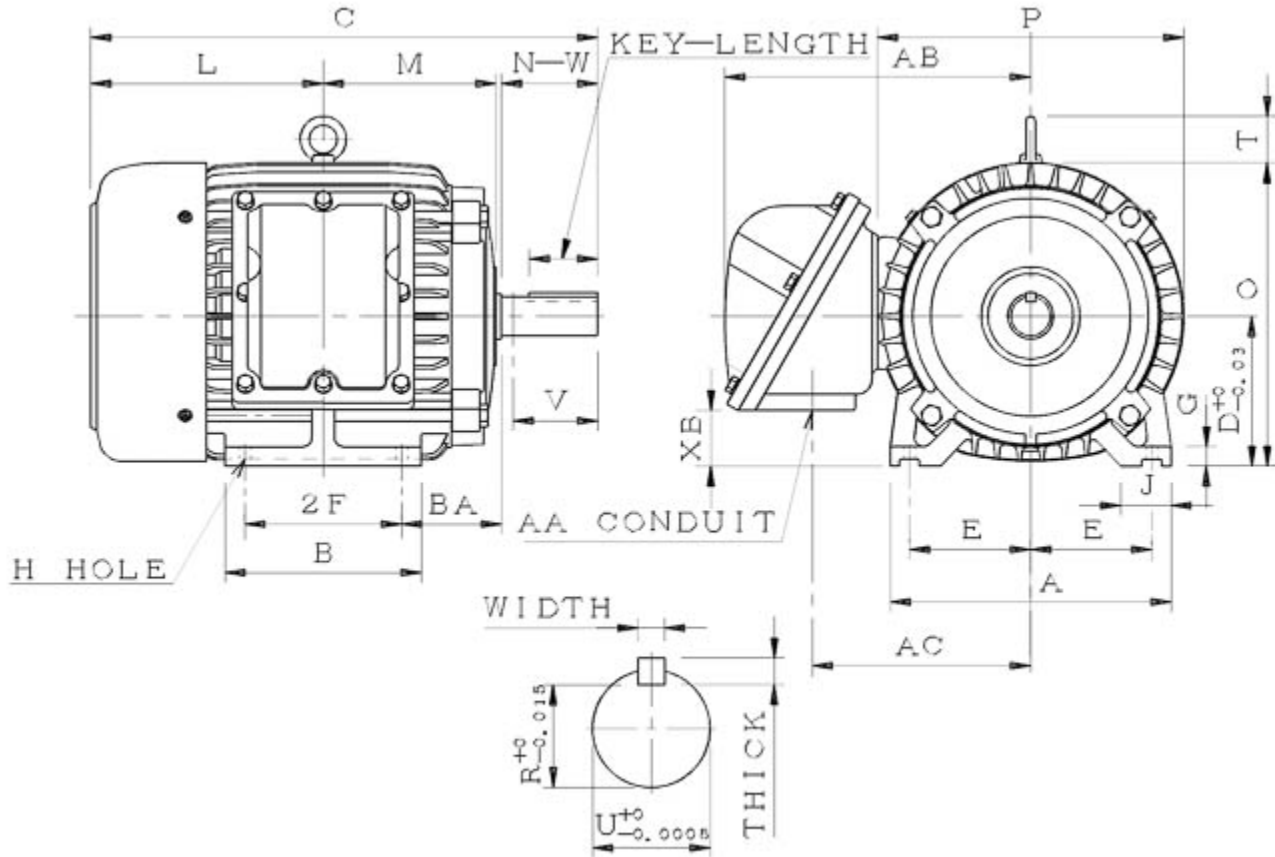

AEHHXV-SMP-3 1 0

Frame Size	Mounting					A	B	C	CD	D	
	E	2F	2F2	H	BA						
213T	4.25	5.5		0.41	3.5	9.85	6.9	18.26		5.25	
G	J	K	L	M	O	P	T	Key			Keyseat
0.7	1.75		8.63	6.02	10.8	11.1	1.45	Width	Thick	Length	R
								0.312	0.312	2.41	1.201
Terminal Housing				Aux Box		C/D Flange					
AA	AB	AC	XB	AE	AX	BB	AH	AK	BD	AJ	BF
NPT1"	10.73	7.45	1.94								
Shaft Extension			Bearings		Approx. Weight Lbs	SPL dBA/3ft	Ins. Class	S.F.	Drive Method	Dimensions	
N-W	U	V	DE	NDE							
3.38	1.375	3.3	6308ZZ	6306ZZ	187	53.0	F	1.15	Direct Coupling / Belt Drive	Inches	

Technical Data Sheet

Motor Type: AEHHXV

Catalogue No: XC00285

Nameplate Information

HP	Pole	RPM	Frame	Voltage	Hz	Phase
2	8	865	213T	575	60	3
Enclosure	Ins. Class	Service Factor	Time Rating	NEMA Design	Rated Amb.	Rated Altitude
TEXP	F	1.15	Continuous	C	°C	<3300 ft

Typical Performance

Efficiency (%)				Power Factor (%)		
Full Load		3/4 Load	1/2 Load	Full Load	3/4 Load	1/2 Load
Nom.	Min.					
84.0	81.5	84.0	82.5	64.0	55.0	42.5
Torque				Current (A)		
Full Load (lb-ft)	Locked Rotor (% FLT)	Pull Up (% FLT)	Break Down (% FLT)	No Load	Full Load	Locked Rotor
12.1	225.0	200.0	275.0	2.0	2.8	20
NEMA KVA Code	Inertia (WR ²)			Safe Stall Time (s)		Noise Level Sound Press. dB(A)
	Rotor (lb-ft ²)	NEMA Load (lb-ft ²)	Max. Allowable (lb-ft ²)	Cold	Hot	
L	0.6	59.5	242.0	60.0	42.0	53.0

VFD Duty Information

Speed Range			VFD		S.F.
Constant Torque	Variable Torque	Constant Power	Carrier	Type	
6-60Hz	3-60Hz	60-90Hz	≤ 5 kHz	VPWM or CPWM	1.0 Only

Additional Information

Bearings		Approx. Weight
DE	NDE	lbs
6308ZZ	6306ZZ	187

Hazardous Locations Information

CSA/UL Certified	
Class I, Div 1, Groups C & D; Class II, Div 1, Groups E, F & G Class I, Zone 1, Groups IIB & IIA; Class II, Div 1, Groups E, F & G	
Temp Code (Sinewave / VFD)	T3B / T3B

Connection Diagram



3 LEAD		SINGLE VOLTAGE			WYE
VOLTAGE	CONN.	L1	L2	L3	
-	WYE	1	2	3	

WD_3Y

Thermal Limit Curves

Motor Type: AEHHXV		Catalogue No: XC00285		Family: Optim TEXP	
HP	2	Safe Stall Time		Full Load A	0.0 / 2.8 A
Voltage	0 / 575V 60Hz	Hot	42.0 s	Locked Rotor A	717 %
RPM	900	Cold	60.0 s	Locked Rotor A	0.0 / 20 A

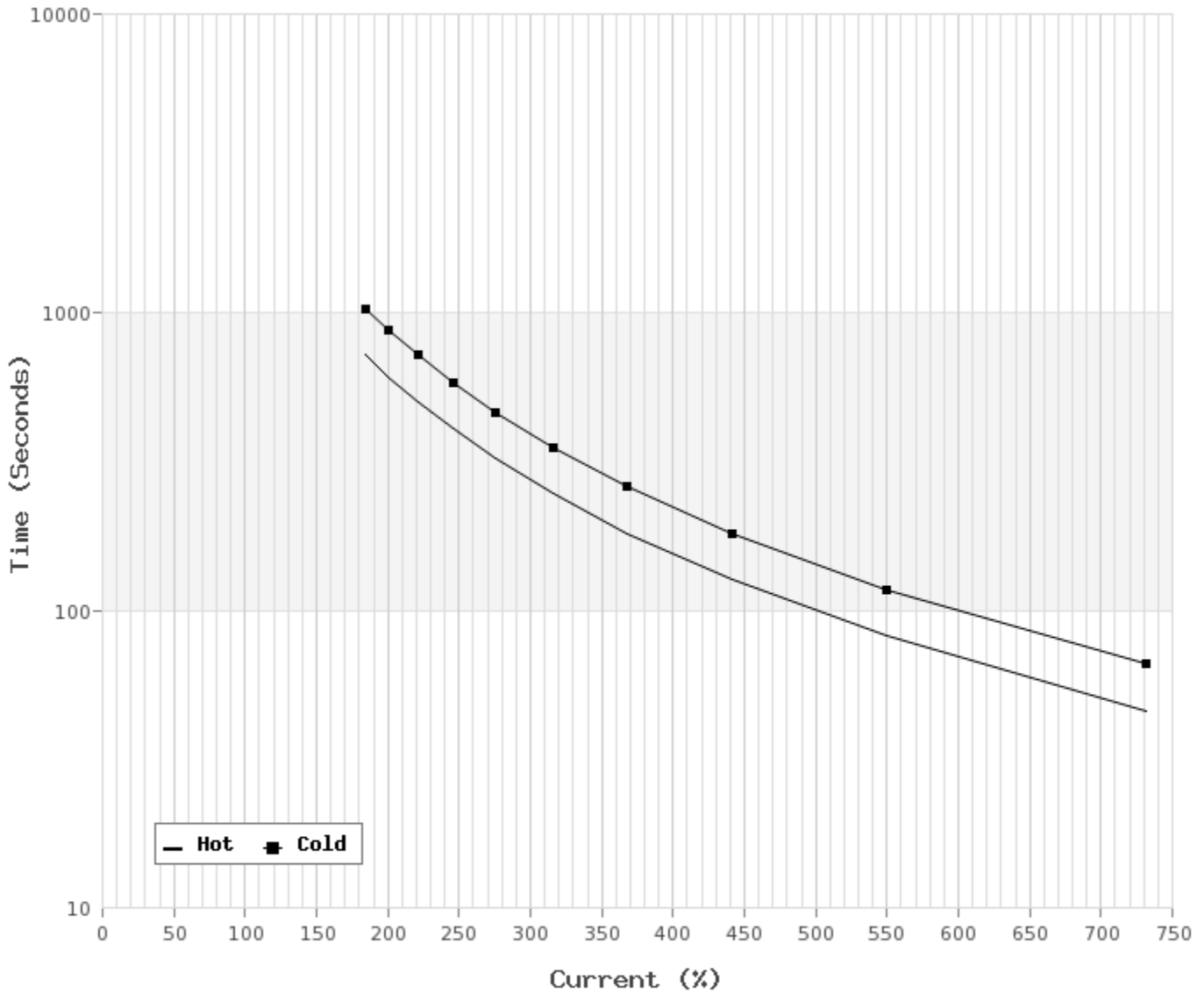

T-N and I-N Curves

Motor Type: AEHHXV		Catalogue No: XC00285		Family: Optim TEXP	
HP	2	Full Load T	12.1 lb-ft	Full Load A	2.8 A
Voltage	575V 60Hz	Locked Rotor T	225.0 %	Locked Rotor A	20.0 A
RPM	900	Pull Up T	200.0 %	Break Down T	275.0 %

