

Technical Documentation

**RD7/565**  
**Rolled Steel ODP | ASGH**

Date: December 1, 2016

**Dimensional Drawing**

Catalogue	Model	HP	Pole	kW	Rating	Voltage	Hz	RPM
RD7/565	ASGH	7.5	6	5.6	Continuous	575 V	60	1200

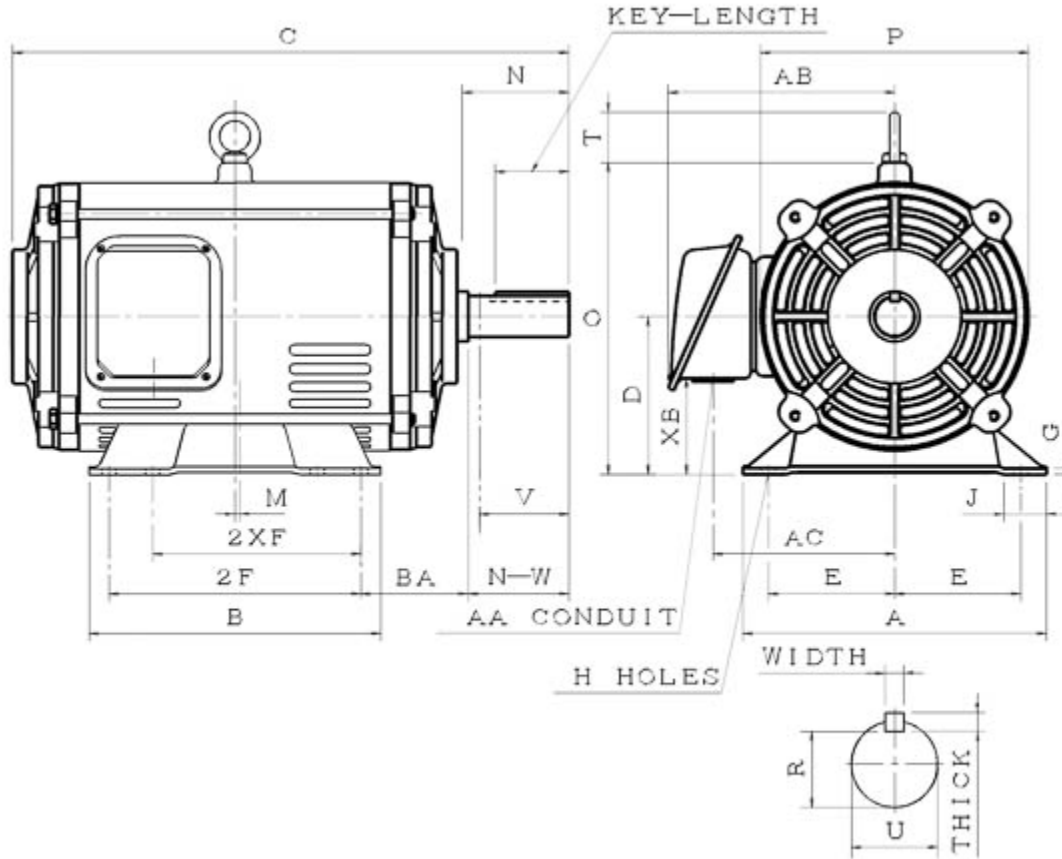

ASGH-SMP-5

Frame Size	Mounting					A	B	C	CD	D	
	E	2F	2F2	H	BA						
254T	10		8.25	0.53	4.25	12.05	11.57	22.48		6.25	
G	J	K	L	M	O	P	T	Key			Keyseat
0.24	1.65			0.197	12.55	10.79	2	Width	Thick	Length	R
								0.375	0.375	2.91	1.416
Terminal Housing				Aux Box		C/D Flange					
AA	AB	AC	XB	AE	AX	BB	AH	AK	BD	AJ	BF
1.38	8.99	7.2	3.81								
Shaft Extension			Bearings		Approx. Weight Lbs	SPL dBA/3ft	Ins. Class	S.F.	Drive Method	Dimensions	
N-W	U	V	DE	NDE							
4	1.625	3.9	6309ZZC3	6208ZZC3	197	61	F	1.15	Direct Coupling / Belt Drive	Inches	

### Technical Data Sheet

Motor Type: ASGH

Catalogue No: RD7/565

#### Nameplate Information

HP	Pole	RPM	Frame	Voltage	Hz	Phase
7.5	6	1170	254T	575	60	3
Enclosure	Ins. Class	Service Factor	Time Rating	NEMA Design	Rated Amb.	Rated Altitude
ODP	F	1.15	Continuous	B	-40 to 40 °C	<3300 ft

#### Typical Performance

Efficiency (%)				Power Factor (%)		
Full Load		3/4 Load	1/2 Load	Full Load	3/4 Load	1/2 Load
Nom.	Min.					
90.2	88.5	88.5	87.0	77.0	70.0	56.5
Torque				Current (A)		
Full Load (lb-ft)	Locked Rotor (% FLT)	Pull Up (% FLT)	Break Down (% FLT)	No Load	Full Load	Locked Rotor
33.66	250	200	260	4.3	8.1	12
NEMA KVA Code	Inertia (WR <sup>2</sup> )			Safe Stall Time (s)		Noise Level Sound Press. dB(A)
	Rotor (lb-ft <sup>2</sup> )	NEMA Load (lb-ft <sup>2</sup> )	Max. Allowable (lb-ft <sup>2</sup> )	Cold	Hot	
H	2.148	104	267	33	23	61

#### VFD Duty Information

Speed Range			VFD		S.F.
Constant Torque	Variable Torque	Constant Power	Carrier	Type	
6-60Hz	3-60Hz	60-120Hz	≤ 5 kHz	VPWM or CPWM	1.0 Only

#### Additional Information

Bearings		Approx. Weight
DE	NDE	lbs
6309ZZC3	6208ZZC3	197

#### Hazardous Locations Information

N/A	
0	
0	
Temp Code (Sinewave / VFD)	0 / 0

**Connection Diagram**



3 LEAD SINGLE VOLTAGE DELTA					
VOLTAGE	CONN.	L1	L2	L3	
-	DELTA	1	2	3	

WD\_3D

**Thermal Limit Curves**

Motor Type: ASGH		Catalogue No: RD7/565		Family: Rolled Steel ODP	
HP	7.5	Safe Stall Time		Full Load A	0.0 / 8.1 A
Voltage	0 / 575V 60Hz	Hot	23 s	Locked Rotor A	148 %
RPM	1200	Cold	33 s	Locked Rotor A	0.0 / 12 A

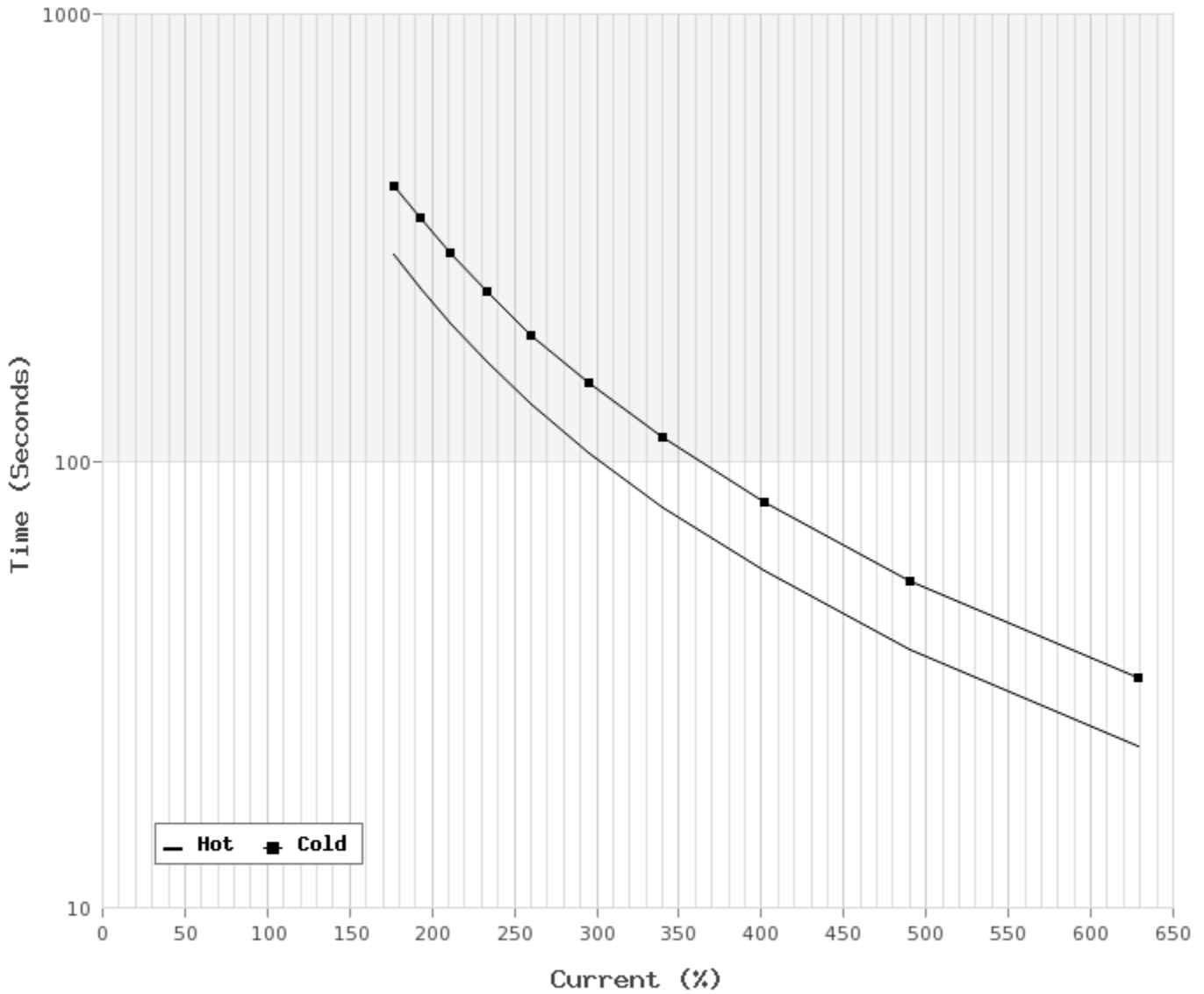

**T-N and I-N Curves**

Motor Type: ASGH		Catalogue No: RD7/565		Family: Rolled Steel ODP	
HP	7.5	Full Load T	33.66 lb-ft	Full Load A	8.1 A
Voltage	575V 60Hz	Locked Rotor T	250 %	Locked Rotor A	12.0 A
RPM	1200	Pull Up T	200 %	Break Down T	260 %

