

Technical Documentation

XC1/52
Optim TEXP | AEHHXV

Date: December 1, 2016

Dimensional Drawing

Catalogue	Model	HP	Pole	kW	Rating	Voltage	Hz	RPM
XC1/52	AEHHXV	1.5	2	1.1	Continuous	230 / 460 V	60	3600

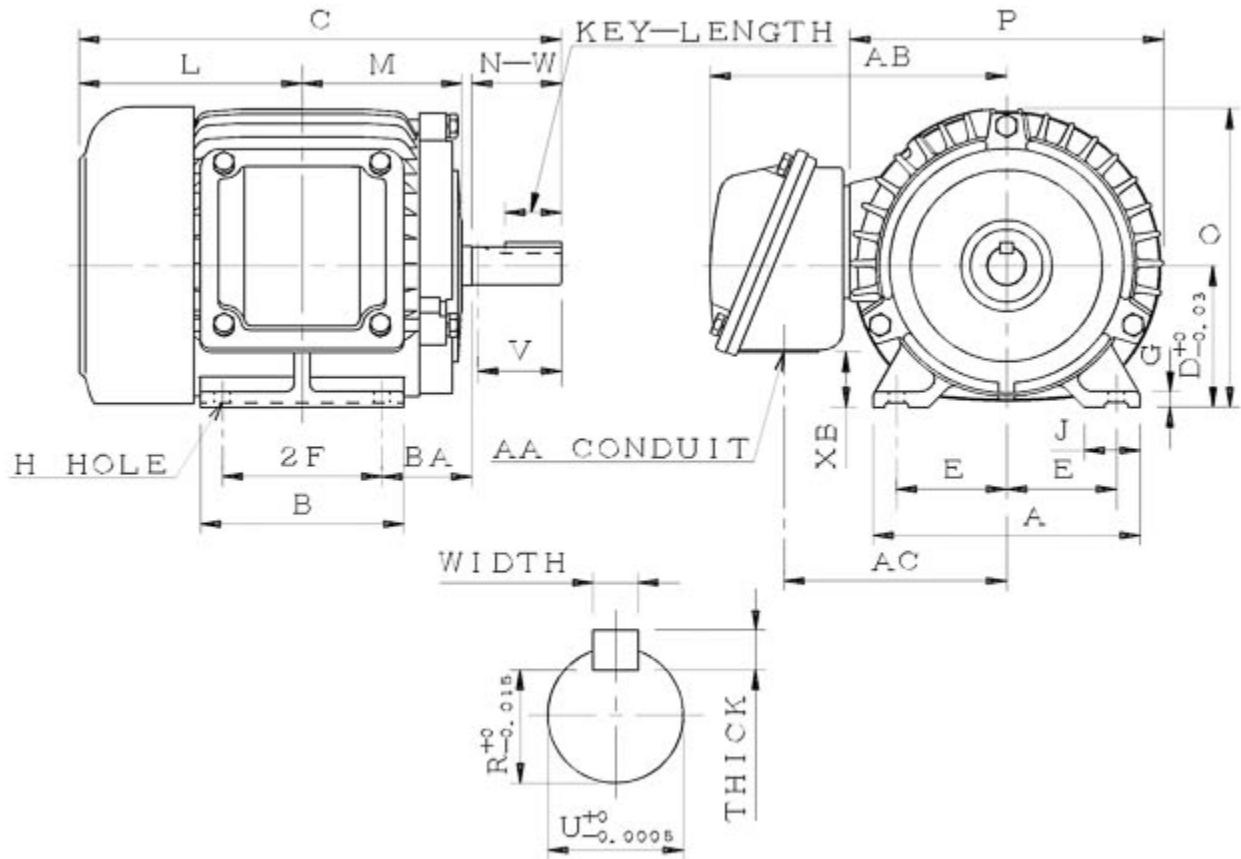

AEHHXV-SMP-1 1 0

Frame Size	Mounting					A	B	C	CD	D	
	E	2F	2F2	H	BA						
143T	2.75	4		0.34	2.25	6.7	5.1	12.56		3.5	
G	J	K	L	M	O	P	T	Key			Keyseat
0.35	1.4		6.06	4.05	7.5	8.03		Width	Thick	Length	R
								0.188	0.188	1.41	0.771
Terminal Housing				Aux Box		C/D Flange					
AA	AB	AC	XB	AE	AX	BB	AH	AK	BD	AJ	BF
NPT3/4"	8.03	5.7	1.33								
Shaft Extension			Bearings		Approx. Weight Lbs	SPL dBA/3ft	Ins. Class	S.F.	Drive Method	Dimensions	
N-W	U	V	DE	NDE							
2.25	0.875	2.2	6205ZZ	6205ZZ	62	65	F	1.15	Direct Coupling / Belt Drive	Inches	

Technical Data Sheet

Motor Type: AEHHXV

Catalogue No: XC1/52

Nameplate Information

HP	Pole	RPM	Frame	Voltage	Hz	Phase
1.5	2	3505	143T	230 / 460	60	3
Enclosure	Ins. Class	Service Factor	Time Rating	NEMA Design	Rated Amb.	Rated Altitude
TEXP	F	1.15	Continuous	B	°C	<3300 ft

Typical Performance

Efficiency (%)				Power Factor (%)		
Full Load		3/4 Load	1/2 Load	Full Load	3/4 Load	1/2 Load
Nom.	Min.					
84.0	81.5	84.0	81.0	84.0	77.0	64.5
Torque				Current (A)		
Full Load (lb-ft)	Locked Rotor (% FLT)	Pull Up (% FLT)	Break Down (% FLT)	No Load	Full Load	Locked Rotor
2	310	255	395	2.1 / 1.0	4.0 / 2.0	40 / 20
NEMA KVA Code	Inertia (WR ²)			Safe Stall Time (s)		Noise Level Sound Press. dB(A)
	Rotor (lb-ft ²)	NEMA Load (lb-ft ²)	Max. Allowable (lb-ft ²)	Cold	Hot	
M	0.052	2	5	17	12	65

VFD Duty Information

Speed Range			VFD		S.F.
Constant Torque	Variable Torque	Constant Power	Carrier	Type	
12-60Hz	3-60Hz	60-90Hz	≤ 5 kHz	VPWM or CPWM	1.0 Only

Additional Information

Bearings		Approx. Weight
DE	NDE	lbs
6205ZZ	6205ZZ	62

Hazardous Locations Information

CSA/UL Certified	
Class I, Div 1, Groups C & D; Class II, Div 1, Groups E, F & G Class I, Zone 1, Groups IIB & IIA; Class II, Div 1, Groups E, F & G	
Temp Code (Sinewave / VFD)	T3B / T3B

Connection Diagram



9 LEAD DUAL VOLTAGE WYE					
VOLTAGE	CONN.	L1	L2	L3	JOIN
HIGH	WYE	1	2	3	4&7,5&8,6&9
LOW	2 WYE	1,7	2,8	3,9	4&5&6

WD_9Y

Thermal Limit Curves

Motor Type: AEHHXV		Catalogue No: XC1/52		Family: Optim TEXP	
HP	1.5	Safe Stall Time		Full Load A	4.0 / 2.0 A
Voltage	230 / 460V 60Hz	Hot	12 s	Locked Rotor A	1,005 / 1,005 %
RPM	3600	Cold	17 s	Locked Rotor A	40.0 / 20 A

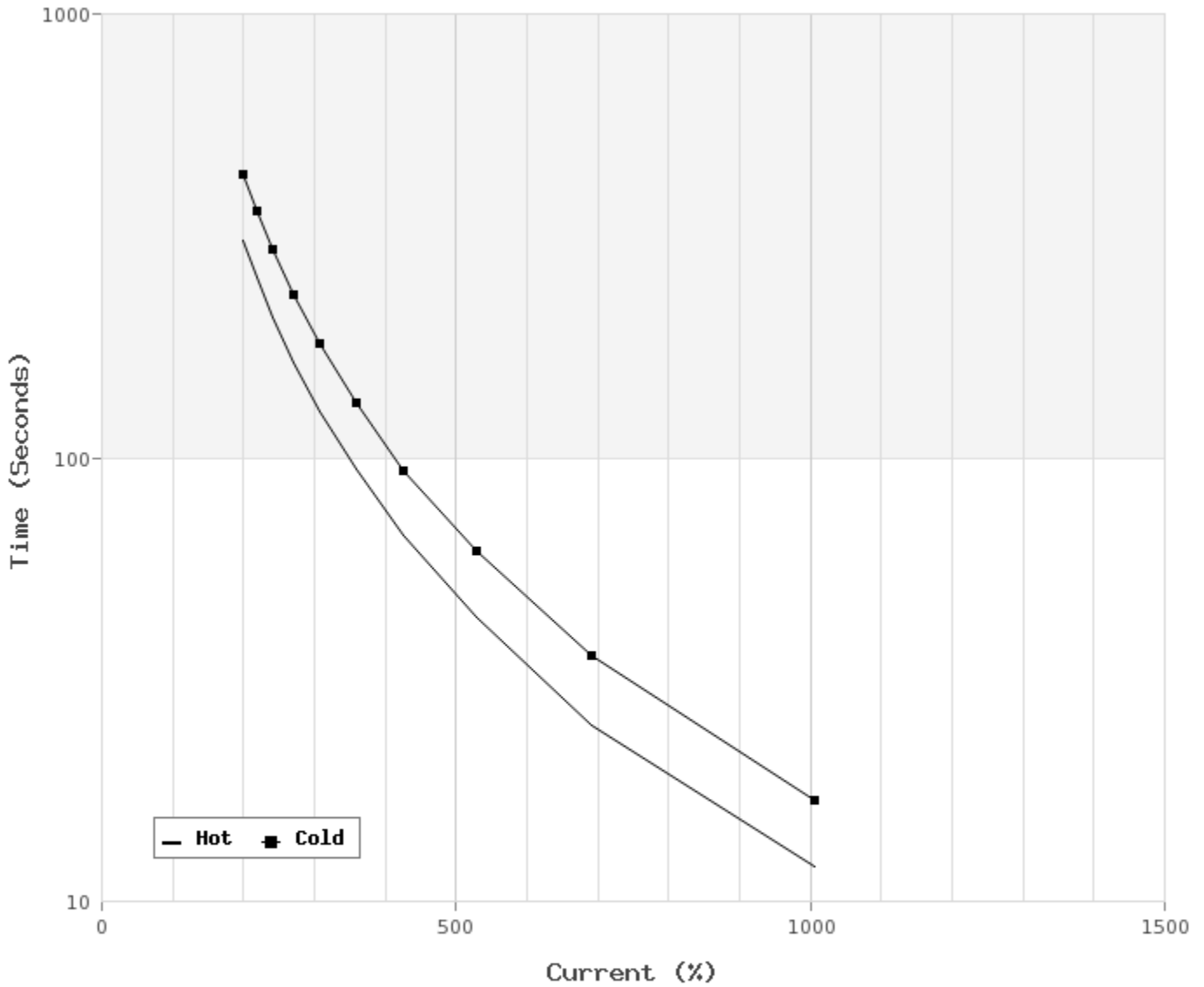

T-N and I-N Curves

Motor Type: AEHHXV		Catalogue No: XC1/52		Family: Optim TEXP	
HP	1.5	Full Load T	2 lb-ft	Full Load A	4.0 / 2.0 A
Voltage	230 / 460V 60Hz	Locked Rotor T	310 %	Locked Rotor A	40.0 / 20.0 A
RPM	3600	Pull Up T	255 %	Break Down T	395 %

