

Technical Documentation

**PDH0408C**  
**Optim TEFC | AEHH8N**

Date: November 30, 2016

**Dimensional Drawing**

Catalogue	Model	HP	Pole	kW	Rating	Voltage	Hz	RPM
PDH0408C	AEHH8N	40	8	30	Continuous	230 / 460 V	60	900

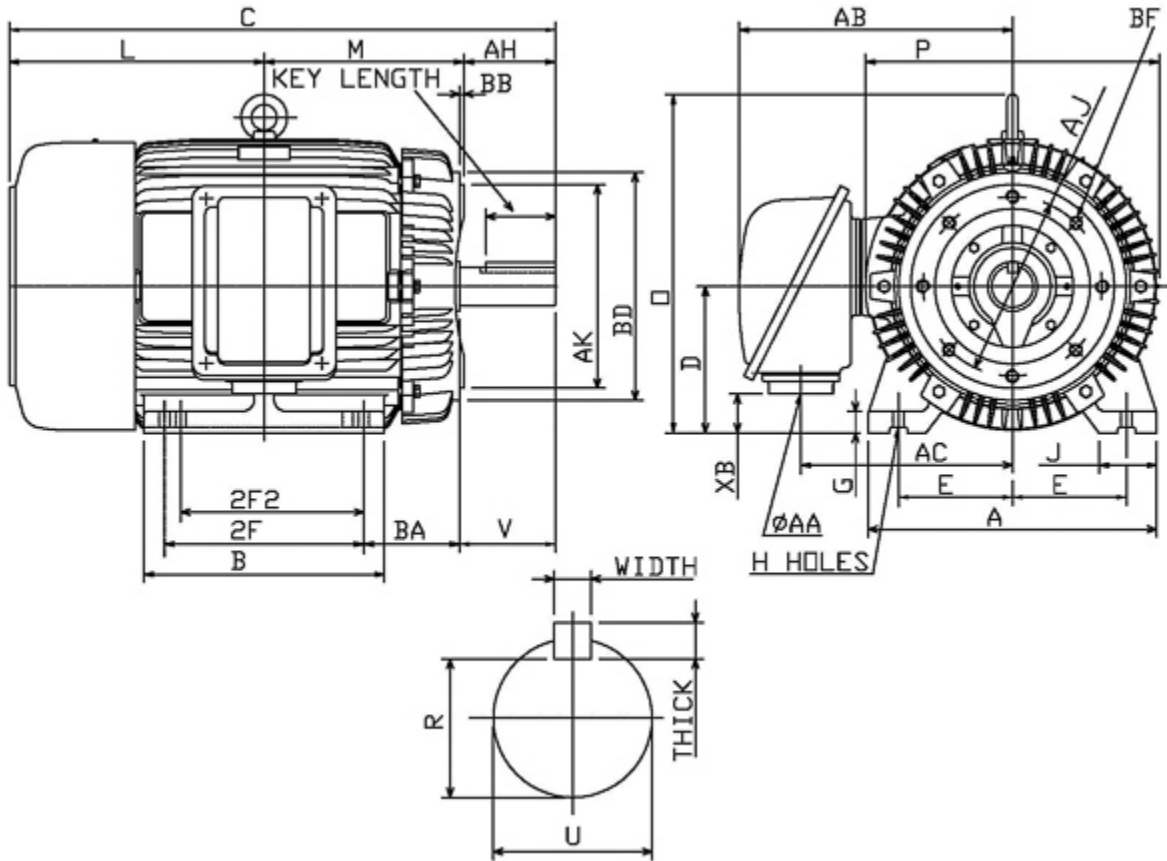

Frame Size	Mounting					A	B	C	CD	D	
	E	2F	2F2	H	BA						
365TC	7	12.25	11.25	0.66	5.88	17.7	14.75	33.55		9	
G	J	K	L	M	O	P	T	Key			Keyseat
1.3	3.55		15.67	11.79	18.02	18.03	2.76	Width	Thick	Length	R
								0.625	0.625	4.28	2.021
Terminal Housing				Aux Box		C/D Flange					
AA	AB	AC	XB	AE	AX	BB	AH	AK	BD	AJ	BF
3 NPT	16.81	13	2.39			0.25	5.63	12.5	14	11	5/8-11UNC
Shaft Extension			Bearings		Approx. Weight Lbs	SPL dBA/3ft	Ins. Class	S.F.	Drive Method	Dimensions	
N-W	U	V	DE	NDE							
5.88	2.375	5.75	6313	6213	922	72	F	1.15	Direct Coupling / Belt Drive	Inches	

### Technical Data Sheet

Motor Type: AEHH8N

Catalogue No: PDH0408C

#### Nameplate Information

HP	Pole	RPM	Frame	Voltage	Hz	Phase
40	8	885	365TC	230 / 460	60	3
Enclosure	Ins. Class	Service Factor	Time Rating	NEMA Design	Rated Amb.	Rated Altitude
TEFC	F	1.15	Continuous	B	-40 to 40 °C	<3300 ft

#### Typical Performance

Efficiency (%)				Power Factor (%)		
Full Load		3/4 Load	1/2 Load	Full Load	3/4 Load	1/2 Load
Nom.	Min.					
91.7	90.2	92.4	91.7	76.5	72.0	61.0
Torque				Current (A)		
Full Load (lb-ft)	Locked Rotor (% FLT)	Pull Up (% FLT)	Break Down (% FLT)	No Load	Full Load	Locked Rotor
237.30	200	150	200	48.6 / 24.3	107.0 / 53.4	580 / 290
NEMA KVA Code	Inertia (WR <sup>2</sup> )			Safe Stall Time (s)		Noise Level Sound Press. dB(A)
	Rotor (lb-ft <sup>2</sup> )	NEMA Load (lb-ft <sup>2</sup> )	Max. Allowable (lb-ft <sup>2</sup> )	Cold	Hot	
G	19.318	1007.0	1923.0	40	28	72

#### VFD Duty Information

Speed Range			VFD		S.F.
Constant Torque	Variable Torque	Constant Power	Carrier	Type	
6-60Hz	3-60Hz	60-120Hz	≤ 5 kHz	VPWM or CPWM	1.0 Only

#### Additional Information

Bearings		Approx. Weight
DE	NDE	lbs
6313	6213	922

#### Hazardous Locations Information

CSA Certified	
Class I, Div 2, Groups B, C & D	
Class I, Zone 2, Groups IIB+H2, IIB & IIA	
Temp Code (Sinewave / VFD)	T3A / T3A

**Connection Diagram**



12 LEAD DUAL VOLTAGE WYE/DELTA						
VOLTAGE	CONNECTION		L1	L2	L3	JOIN
HIGH	START	WYE	1	2	3	4&7,5&8,6&9 10&11&12
	RUN	DELTA	1,12	2,10	3,11	4&7,5&8,6&9
LOW	START	2 WYE	1,7	2,8	3,9	4&5&6 10&11&12
	RUN	2 DELTA	1,6,7 12	2,4,8 10	3,5,9 11	

WD\_12YD

**Thermal Limit Curves**

Motor Type: AEHH8N		Catalogue No: PDH0408C		Family: Optim TEFC	
HP	40	Safe Stall Time		Full Load A	107.0 / 53.4 A
Voltage	230 / 460V 60Hz	Hot	28 s	Locked Rotor A	542 / 543 %
RPM	900	Cold	40 s	Locked Rotor A	580.0 / 290 A

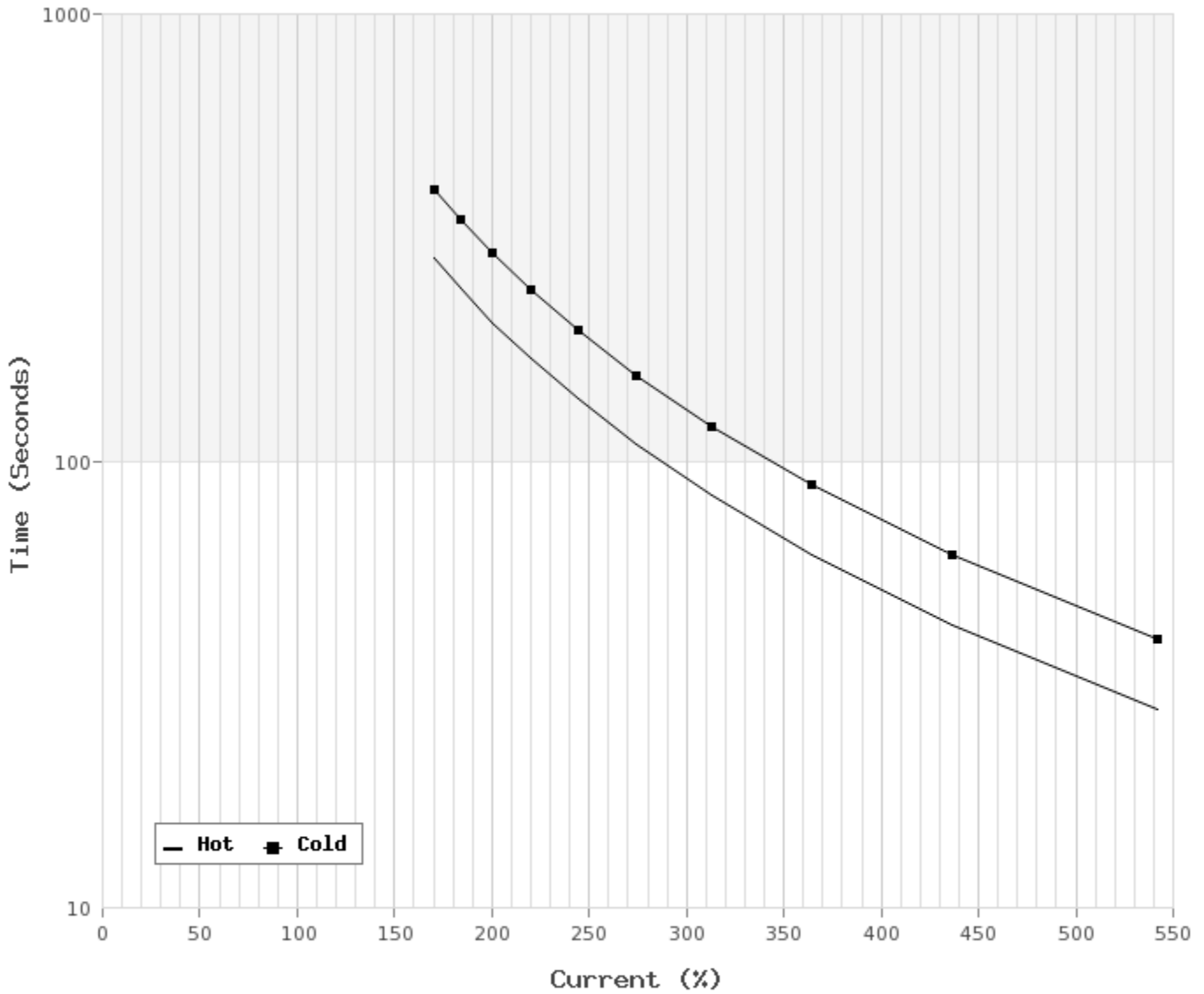

**T-N and I-N Curves**

Motor Type: AEHH8N		Catalogue No: PDH0408C		Family: Optim TEFC	
HP	40	Full Load T	237.30 lb-ft	Full Load A	107.0 / 53.4 A
Voltage	230 / 460V 60Hz	Locked Rotor T	200 %	Locked Rotor A	580.0 / 290.0 A
RPM	900	Pull Up T	150 %	Break Down T	200 %

