

Technical Documentation

PDH0058C

Optim TEFC | AEHH8N

Date: November 30, 2016

Dimensional Drawing

Catalogue	Model	HP	Pole	kW	Rating	Voltage	Hz	RPM
PDH0058C	AEHH8N	5	8	3.7	Continuous	230 / 460 V	60	900

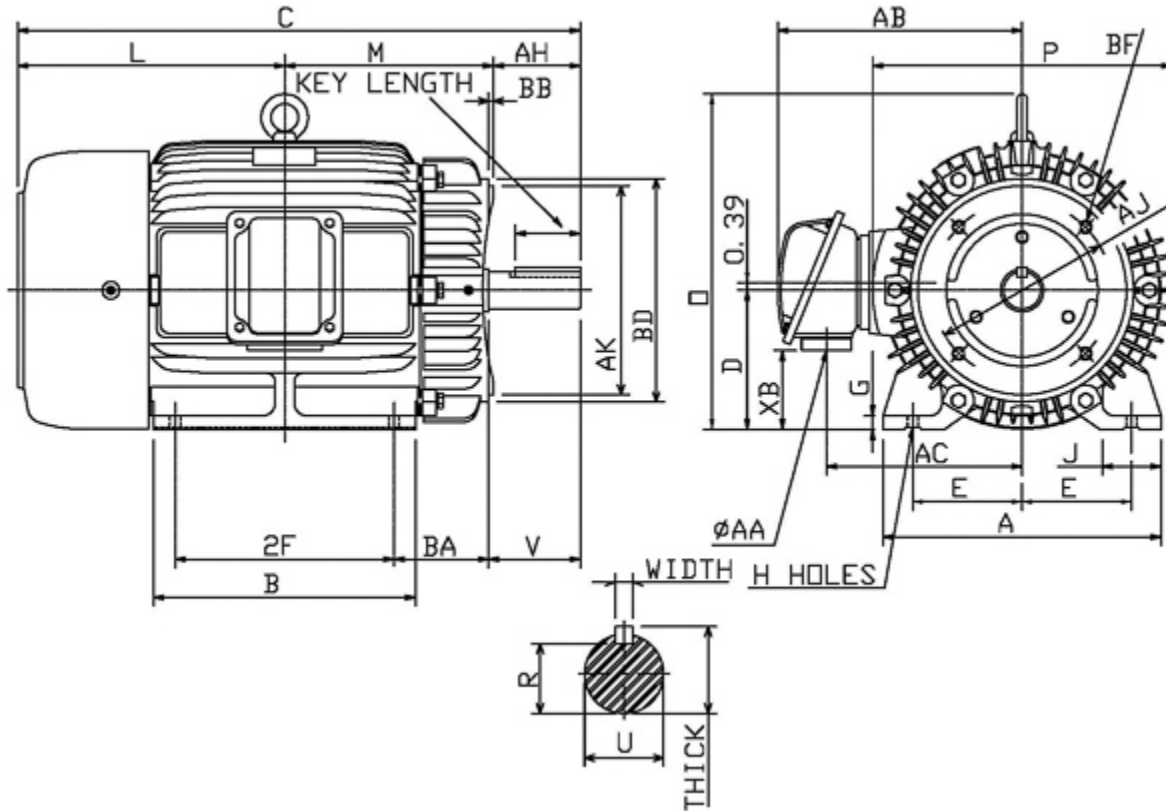

Frame Size	Mounting					A	B	C	CD	D	
	E	2F	2F2	H	BA						
254TC	5	8.25		0.53	4.25	11.8	9.85	23.7		6.25	
G	J	K	L	M	O	P	T	Key			Keyseat R
								Width	Thick	Length	
0.65	1.95		11.33	8.06	12.83	13.15	1.97	0.375	0.375	2.91	1.416
Terminal Housing			Aux Box			C/D Flange					
AA	AB	AC	XB	AE	AX	BB	AH	AK	BD	AJ	BF
1.25 NPT	11.3	8.86	3.22			0.25	3.75	8.5	9.92	7.25	1/2-13UNC
Shaft Extension			Bearings		Approx. Weight Lbs	SPL dBA/3ft	Ins. Class	S.F.	Drive Method	Dimensions	
N-W	U	V	DE	NDE							
4	1.625	3.9	6309ZZ	6307ZZ	257	54	F	1.15	Direct Coupling / Belt Drive	Inches	

Technical Data Sheet

Motor Type: AEHH8N

Catalogue No: PDH0058C

Nameplate Information

HP	Pole	RPM	Frame	Voltage	Hz	Phase
5	8	870	254TC	230 / 460	60	3
Enclosure	Ins. Class	Service Factor	Time Rating	NEMA Design	Rated Amb.	Rated Altitude
TEFC	F	1.15	Continuous	B	-40 to 40 °C	<3300 ft

Typical Performance

Efficiency (%)				Power Factor (%)		
Full Load		3/4 Load	1/2 Load	Full Load	3/4 Load	1/2 Load
Nom.	Min.					
86.5	84.0	86.5	85.5	72.0	64.0	51.5
Torque				Current (A)		
Full Load (lb-ft)	Locked Rotor (% FLT)	Pull Up (% FLT)	Break Down (% FLT)	No Load	Full Load	Locked Rotor
30.17	190	185	240	9.3 / 4.6	15.0 / 7.5	92 / 46
NEMA KVA Code	Inertia (WR ²)			Safe Stall Time (s)		Noise Level Sound Press. dB(A)
	Rotor (lb-ft ²)	NEMA Load (lb-ft ²)	Max. Allowable (lb-ft ²)	Cold	Hot	
J	1.660	142.0	353.0	46	33	54

VFD Duty Information

Speed Range			VFD		S.F.
Constant Torque	Variable Torque	Constant Power	Carrier	Type	
6-60Hz	3-60Hz	60-120Hz	≤ 5 kHz	VPWM or CPWM	1.0 Only

Additional Information

Bearings		Approx. Weight
DE	NDE	lbs
6309ZZ	6307ZZ	257

Hazardous Locations Information

CSA Certified	
Class I, Div 2, Groups B, C & D	
Class I, Zone 2, Groups IIB+H2, IIB & IIA	
Temp Code (Sinewave / VFD)	T3A / T3A

Connection Diagram



9 LEAD DUAL VOLTAGE WYE					
VOLTAGE	CONN.	L1	L2	L3	JOIN
HIGH	WYE	1	2	3	4&7,5&8,6&9
LOW	2 WYE	1,7	2,8	3,9	4&5&6

WD_9Y

Thermal Limit Curves

Motor Type: AEHH8N		Catalogue No: PDH0058C		Family: Optim TEFC	
HP	5	Safe Stall Time		Full Load A	15.0 / 7.5 A
Voltage	230 / 460V 60Hz	Hot	33 s	Locked Rotor A	613 / 612 %
RPM	900	Cold	46 s	Locked Rotor A	92.0 / 46 A

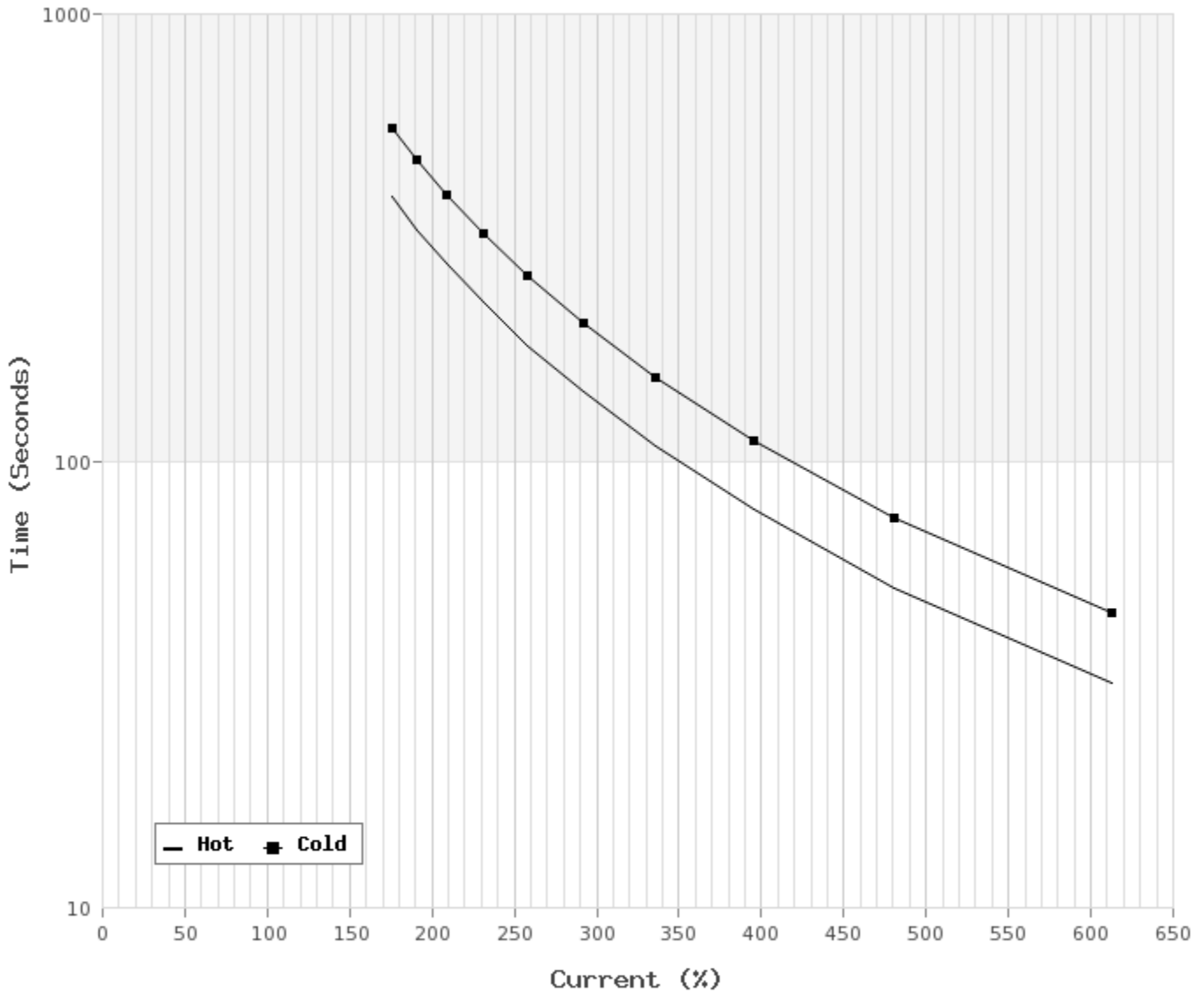

T-N and I-N Curves

Motor Type: AEHH8N		Catalogue No: PDH0058C		Family: Optim TEFC	
HP	5	Full Load T	30.17 lb-ft	Full Load A	15.0 / 7.5 A
Voltage	230 / 460V 60Hz	Locked Rotor T	190 %	Locked Rotor A	92.0 / 46.0 A
RPM	900	Pull Up T	185 %	Break Down T	240 %

