

Technical Documentation

PDH0108C

Optim TEFC | AEHH8N

Date: November 30, 2016

Dimensional Drawing

Catalogue	Model	HP	Pole	kW	Rating	Voltage	Hz	RPM
PDH0108C	AEHH8N	10	8	7.5	Continuous	230 / 460 V	60	900

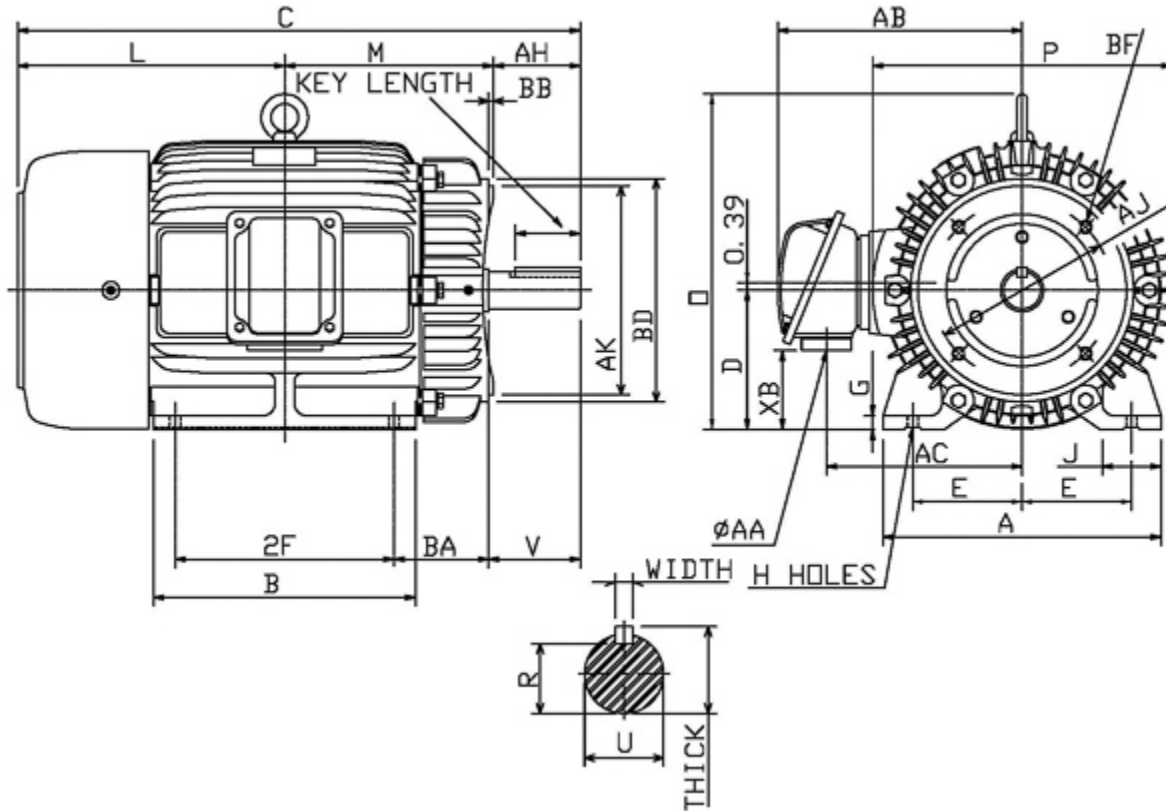

Frame Size	Mounting					A	B	C	CD	D	
	E	2F	2F2	H	BA						
284TC	5.5	9.5		0.53	4.75	14	11.7	26.8		7	
G	J	K	L	M	O	P	T	Key			Keyseat
0.7	2.95		12.68	9.23	14.52	15.04	1.97	Width	Thick	Length	R
								0.5	0.5	3.28	1.591
Terminal Housing				Aux Box		C/D Flange					
AA	AB	AC	XB	AE	AX	BB	AH	AK	BD	AJ	BF
1.25 NPT	12.28	9.84	3.97			0.25	4.37	10.5	11.22	9	1/2-13UNC
Shaft Extension			Bearings		Approx. Weight Lbs	SPL dBA/3ft	Ins. Class	S.F.	Drive Method	Dimensions	
N-W	U	V	DE	NDE							
4.62	1.875	4.5	6311ZZ	6310ZZ	407	59	F	1.15	Direct Coupling / Belt Drive	Inches	

Technical Data Sheet

Motor Type: AEHH8N

Catalogue No: PDH0108C

Nameplate Information

HP	Pole	RPM	Frame	Voltage	Hz	Phase
10	8	885	284TC	230 / 460	60	3
Enclosure	Ins. Class	Service Factor	Time Rating	NEMA Design	Rated Amb.	Rated Altitude
TEFC	F	1.15	Continuous	B	-40 to 40 °C	<3300 ft

Typical Performance

Efficiency (%)				Power Factor (%)		
Full Load		3/4 Load	1/2 Load	Full Load	3/4 Load	1/2 Load
Nom.	Min.					
89.5	87.5	89.5	87.5	73.5	66.0	53.5
Torque				Current (A)		
Full Load (lb-ft)	Locked Rotor (% FLT)	Pull Up (% FLT)	Break Down (% FLT)	No Load	Full Load	Locked Rotor
59.33	235	210	280	16.4 / 8.2	28.5 / 14.2	162 / 81
NEMA KVA Code	Inertia (WR ²)			Safe Stall Time (s)		Noise Level Sound Press. dB(A)
	Rotor (lb-ft ²)	NEMA Load (lb-ft ²)	Max. Allowable (lb-ft ²)	Cold	Hot	
H	5.421	273.0	588.0	32	22	59

VFD Duty Information

Speed Range			VFD		S.F.
Constant Torque	Variable Torque	Constant Power	Carrier	Type	
6-60Hz	3-60Hz	60-120Hz	≤ 5 kHz	VPWM or CPWM	1.0 Only

Additional Information

Bearings		Approx. Weight
DE	NDE	lbs
6311ZZ	6310ZZ	407

Hazardous Locations Information

CSA Certified	
Class I, Div 2, Groups B, C & D Class I, Zone 2, Groups IIB+H2, IIB & IIA	
Temp Code (Sinewave / VFD)	T3A / T3A

Connection Diagram



12 LEAD DUAL VOLTAGE WYE/DELTA						
VOLTAGE	CONNECTION		L1	L2	L3	JOIN
HIGH	START	WYE	1	2	3	4&7,5&8,6&9 10&11&12
	RUN	DELTA	1,12	2,10	3,11	4&7,5&8,6&9
LOW	START	2 WYE	1,7	2,8	3,9	4&5&6 10&11&12
	RUN	2 DELTA	1,6,7 12	2,4,8 10	3,5,9 11	

WD_12YD

Thermal Limit Curves

Motor Type: AEHH8N		Catalogue No: PDH0108C		Family: Optim TEFC	
HP	10	Safe Stall Time		Full Load A	28.5 / 14.2 A
Voltage	230 / 460V 60Hz	Hot	22 s	Locked Rotor A	568 / 569 %
RPM	900	Cold	32 s	Locked Rotor A	162.0 / 81 A

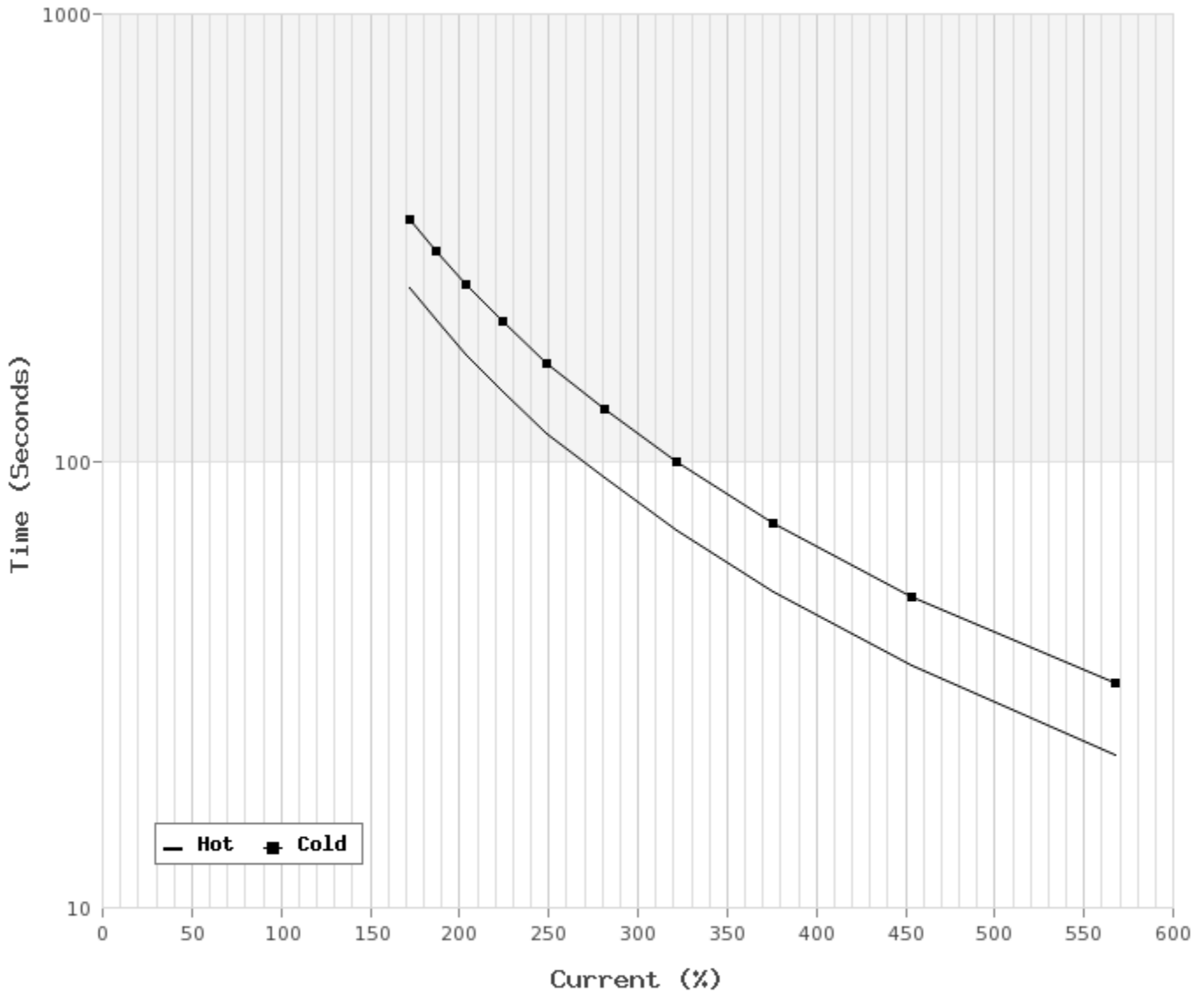

T-N and I-N Curves

Motor Type: AEHH8N		Catalogue No: PDH0108C		Family: Optim TEFC	
HP	10	Full Load T	59.33 lb-ft	Full Load A	28.5 / 14.2 A
Voltage	230 / 460V 60Hz	Locked Rotor T	235 %	Locked Rotor A	162.0 / 81.0 A
RPM	900	Pull Up T	210 %	Break Down T	280 %

