

Technical Documentation

PDH05085C
Optim TEFC | AEHH8N

Date: November 30, 2016

Dimensional Drawing

Catalogue	Model	HP	Pole	kW	Rating	Voltage	Hz	RPM
PDH05085C	AEHH8N	50	8	37	Continuous	575 V	60	900

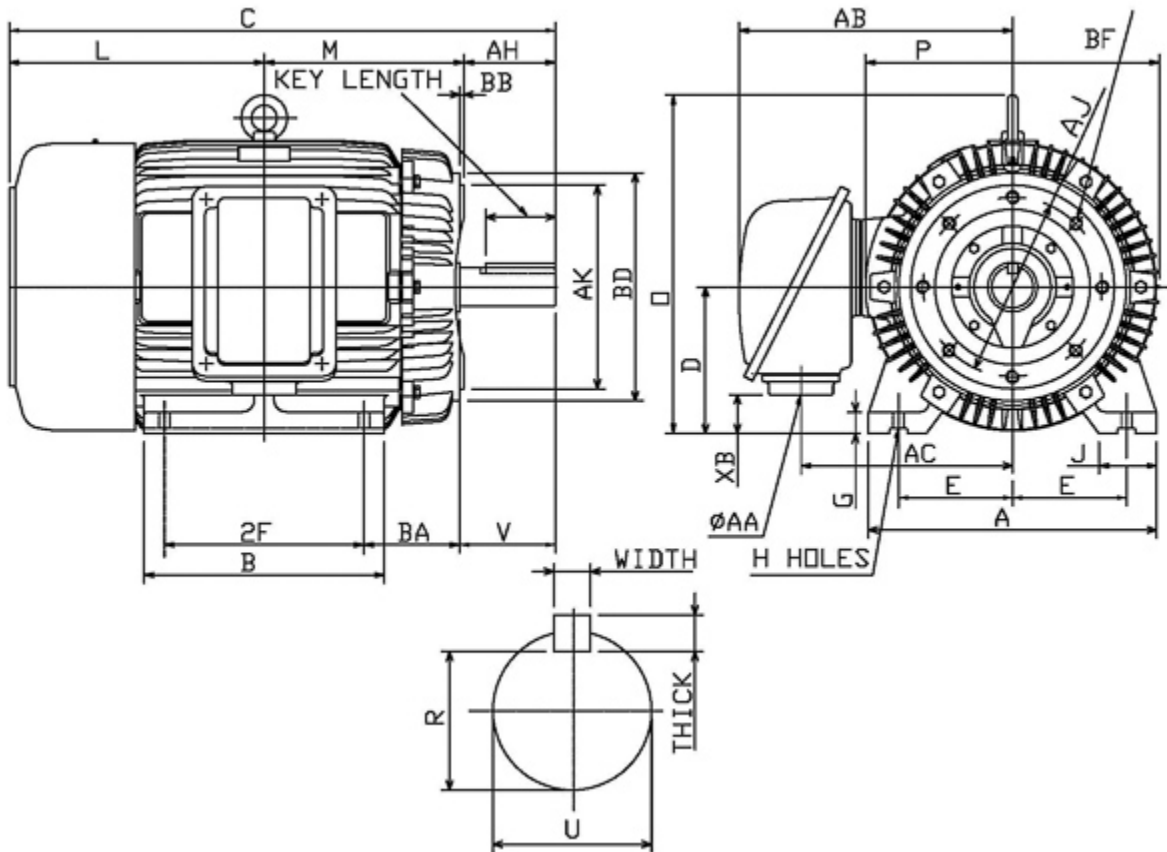

Frame Size	Mounting					A	B	C	CD	D	
	E	2F	2F2	H	BA						
404TC	8	12.25		0.81	6.62	19.7	15.15	36.3		10	
G	J	K	L	M	O	P	T	Key			Keyseat R
								Width	Thick	Length	
1.55	3.95		16.3	12.52	20.04	20.08	2.76	0.75	0.75	5.65	2.45
Terminal Housing			Aux Box			C/D Flange					
AA	AB	AC	XB	AE	AX	BB	AH	AK	BD	AJ	BF
3 NPT	19.37	14.76	1.81			0.25	7	12.5	15.27	11	5/8-11UNC
Shaft Extension			Bearings		Approx. Weight Lbs	SPL dBA/3ft	Ins. Class	S.F.	Drive Method	Dimensions	
N-W	U	V	DE	NDE							
7.25	2.875	7.15	6317	6313	1232	73	F	1.15	Direct Coupling / Belt Drive	Inches	

Technical Data Sheet

Motor Type: AEHH8N

Catalogue No: PDH05085C

Nameplate Information

HP	Pole	RPM	Frame	Voltage	Hz	Phase
50	8	885	404TC	575	60	3
Enclosure	Ins. Class	Service Factor	Time Rating	NEMA Design	Rated Amb.	Rated Altitude
TEFC	F	1.15	Continuous	B	-40 to 40 °C	<3300 ft

Typical Performance

Efficiency (%)				Power Factor (%)		
Full Load		3/4 Load	1/2 Load	Full Load	3/4 Load	1/2 Load
Nom.	Min.					
93.0	91.7	93.6	93.0	80.5	77.0	67.5
Torque				Current (A)		
Full Load (lb-ft)	Locked Rotor (% FLT)	Pull Up (% FLT)	Break Down (% FLT)	No Load	Full Load	Locked Rotor
296.60	200	175	230	19.5	50.0	290
NEMA KVA Code	Inertia (WR ²)			Safe Stall Time (s)		Noise Level Sound Press. dB(A)
	Rotor (lb-ft ²)	NEMA Load (lb-ft ²)	Max. Allowable (lb-ft ²)	Cold	Hot	
G	31.465	1241.0	2666.0	36	25	73

VFD Duty Information

Speed Range			VFD		S.F.
Constant Torque	Variable Torque	Constant Power	Carrier	Type	
6-60Hz	3-60Hz	60-120Hz	≤ 5 kHz	VPWM or CPWM	1.0 Only

Additional Information

Bearings		Approx. Weight
DE	NDE	lbs
6317	6313	1232

Hazardous Locations Information

CSA Certified	
Class I, Div 2, Groups B, C & D	
Class I, Zone 2, Groups IIB+H2, IIB & IIA	
Temp Code (Sinewave / VFD)	T3A / T3A

Connection Diagram



3 LEAD SINGLE VOLTAGE DELTA					
VOLTAGE	CONN.	L1	L2	L3	
-	DELTA	1	2	3	

WD_3D

Thermal Limit Curves

Motor Type: AEHH8N		Catalogue No: PDH05085C		Family: Optim TEFC	
HP	50	Safe Stall Time		Full Load A	0.0 / 50.0 A
Voltage	0 / 575V 60Hz	Hot	25 s	Locked Rotor A	580 %
RPM	900	Cold	36 s	Locked Rotor A	0.0 / 290 A

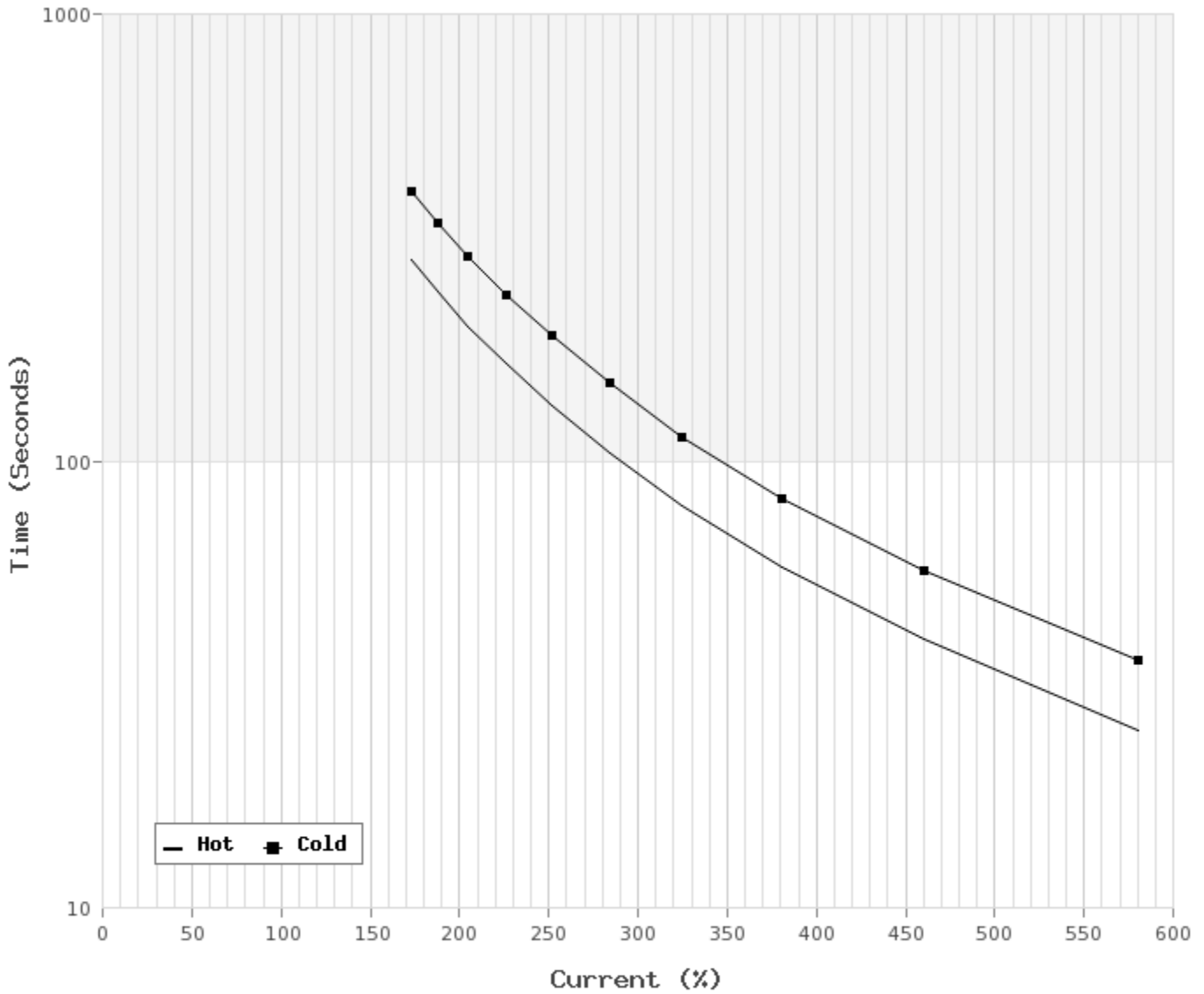

T-N and I-N Curves

Motor Type: AEHH8N		Catalogue No: PDH05085C		Family: Optim TEFC	
HP	50	Full Load T	296.60 lb-ft	Full Load A	50.0 A
Voltage	575V 60Hz	Locked Rotor T	200 %	Locked Rotor A	290.0 A
RPM	900	Pull Up T	175 %	Break Down T	230 %

