

Technical Documentation

# **PDH01585C**

## **Optim TEFC | AEHH8N**

Date: November 30, 2016

### Dimensional Drawing

Catalogue	Model	HP	Pole	kW	Rating	Voltage	Hz	RPM
PDH01585C	AEHH8N	15	8	11	Continuous	575 V	60	900

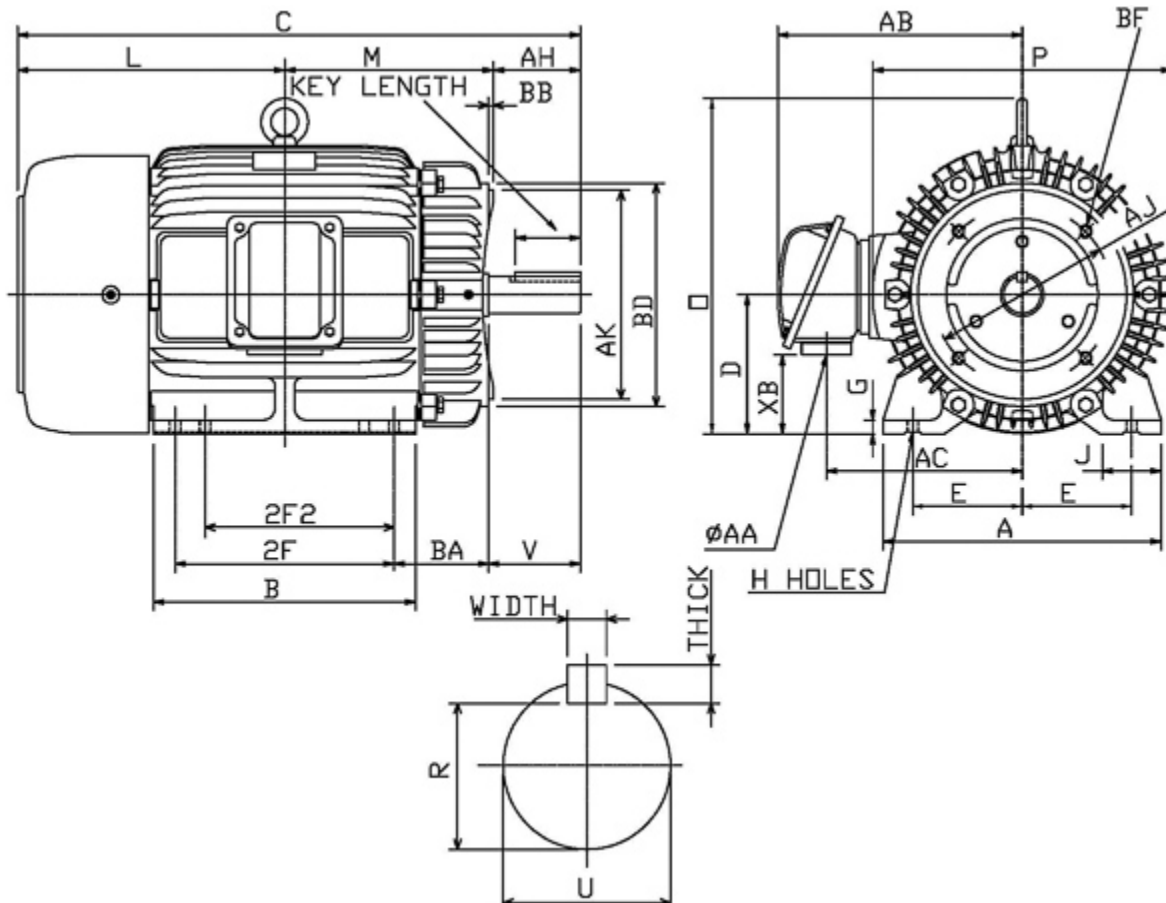

Frame Size	Mounting					A	B	C	CD	D	
	E	2F	2F2	H	BA						
286TC	5.5	11	9.5	0.53	4.75	14	13.2	28.3		7	
G	J	K	L	M	O	P	T	Key			Keyseat
0.7	2.95		13.43	9.98	14.52	15.04	1.97	Width	Thick	Length	R
								0.5	0.5	3.28	1.591
Terminal Housing				Aux Box		C/D Flange					
AA	AB	AC	XB	AE	AX	BB	AH	AK	BD	AJ	BF
1.25 NPT	12.28	9.84	3.97			0.25	4.37	10.5	11.22	9	1/2-13UNC
Shaft Extension			Bearings		Approx. Weight Lbs	SPL dBA/3ft	Ins. Class	S.F.	Drive Method	Dimensions	
N-W	U	V	DE	NDE							
4.62	1.875	4.5	6311ZZ	6310ZZ	449	64	F	1.15	Direct Coupling / Belt Drive	Inches	

### Technical Data Sheet

Motor Type: AEHH8N

Catalogue No: PDH01585C

#### Nameplate Information

HP	Pole	RPM	Frame	Voltage	Hz	Phase
15	8	880	286TC	575	60	3
Enclosure	Ins. Class	Service Factor	Time Rating	NEMA Design	Rated Amb.	Rated Altitude
TEFC	F	1.15	Continuous	B	-40 to 40 °C	<3300 ft

#### Typical Performance

Efficiency (%)				Power Factor (%)		
Full Load		3/4 Load	1/2 Load	Full Load	3/4 Load	1/2 Load
Nom.	Min.					
89.5	87.5	90.2	90.2	78.0	73.0	62.0
Torque				Current (A)		
Full Load (lb-ft)	Locked Rotor (% FLT)	Pull Up (% FLT)	Break Down (% FLT)	No Load	Full Load	Locked Rotor
89.49	180	170	225	8.0	16.1	93
NEMA KVA Code	Inertia (WR <sup>2</sup> )			Safe Stall Time (s)		Noise Level Sound Press. dB(A)
	Rotor (lb-ft <sup>2</sup> )	NEMA Load (lb-ft <sup>2</sup> )	Max. Allowable (lb-ft <sup>2</sup> )	Cold	Hot	
G	7.961	400.0	739.0	28	20	64

#### VFD Duty Information

Speed Range			VFD		S.F.
Constant Torque	Variable Torque	Constant Power	Carrier	Type	
6-60Hz	3-60Hz	60-120Hz	≤ 5 kHz	VPWM or CPWM	1.0 Only

#### Additional Information

Bearings		Approx. Weight
DE	NDE	lbs
6311ZZ	6310ZZ	449

#### Hazardous Locations Information

CSA Certified	
Class I, Div 2, Groups B, C & D	
Class I, Zone 2, Groups IIB+H2, IIB & IIA	
Temp Code (Sinewave / VFD)	T3A / T3A

**Connection Diagram**



3 LEAD SINGLE VOLTAGE DELTA					
VOLTAGE	CONN.	L1	L2	L3	
-	DELTA	1	2	3	

WD\_3D

**Thermal Limit Curves**

Motor Type: AEHH8N		Catalogue No: PDH01585C		Family: Optim TEFC	
HP	15	Safe Stall Time		Full Load A	0.0 / 16.1 A
Voltage	0 / 575V 60Hz	Hot	20 s	Locked Rotor A	578 %
RPM	900	Cold	28 s	Locked Rotor A	0.0 / 93 A

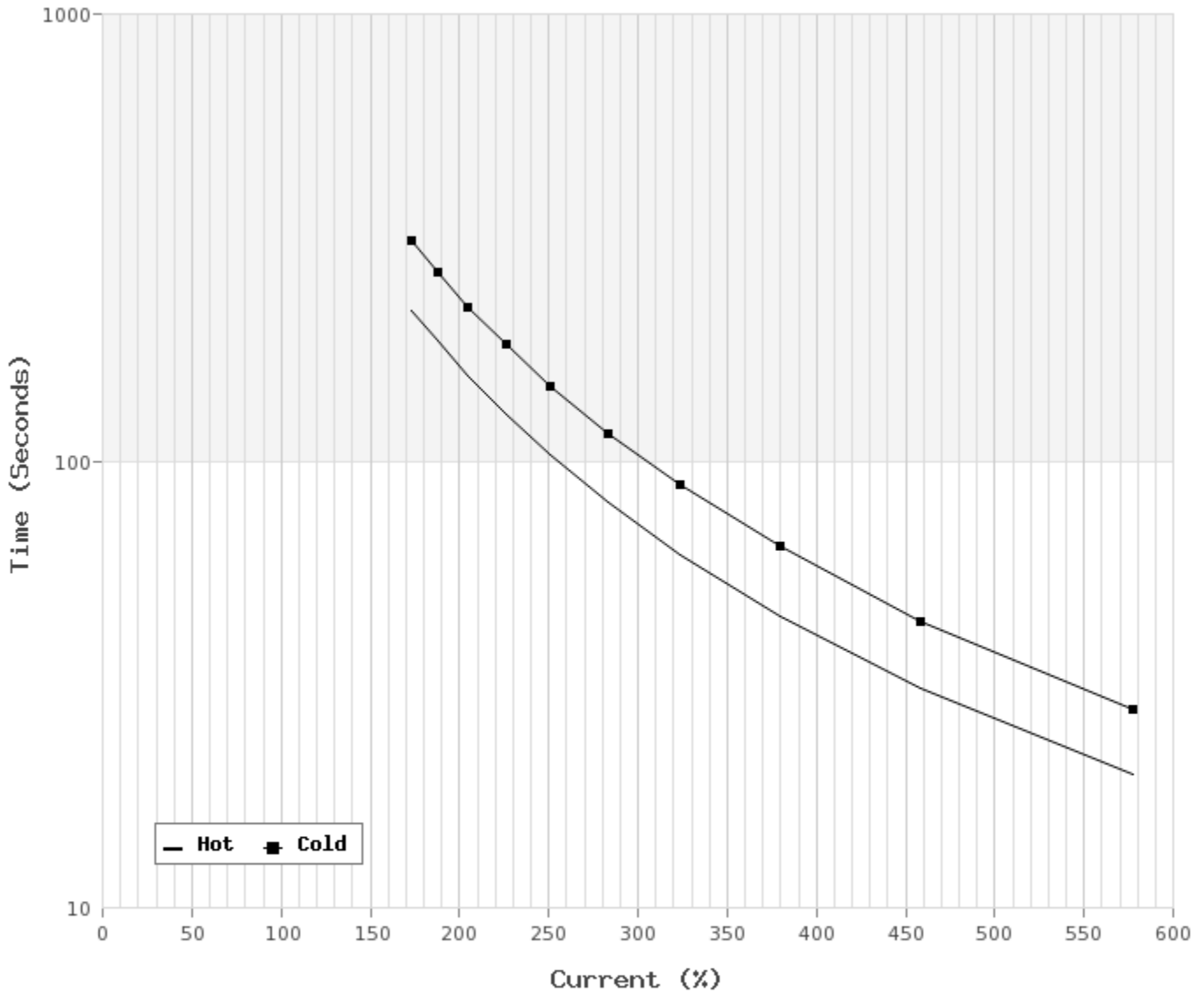

**T-N and I-N Curves**

Motor Type: AEHH8N		Catalogue No: PDH01585C		Family: Optim TEFC	
HP	15	Full Load T	89.49 lb-ft	Full Load A	16.1 A
Voltage	575V 60Hz	Locked Rotor T	180 %	Locked Rotor A	93.0 A
RPM	900	Pull Up T	170 %	Break Down T	225 %

