

Technical Documentation

PDH00365
Optim TEFC | AEHH8N

Date: November 30, 2016

Dimensional Drawing

Catalogue	Model	HP	Pole	kW	Rating	Voltage	Hz	RPM
PDH00365	AEHH8N	3	6	2.2	Continuous	575 V	60	1200

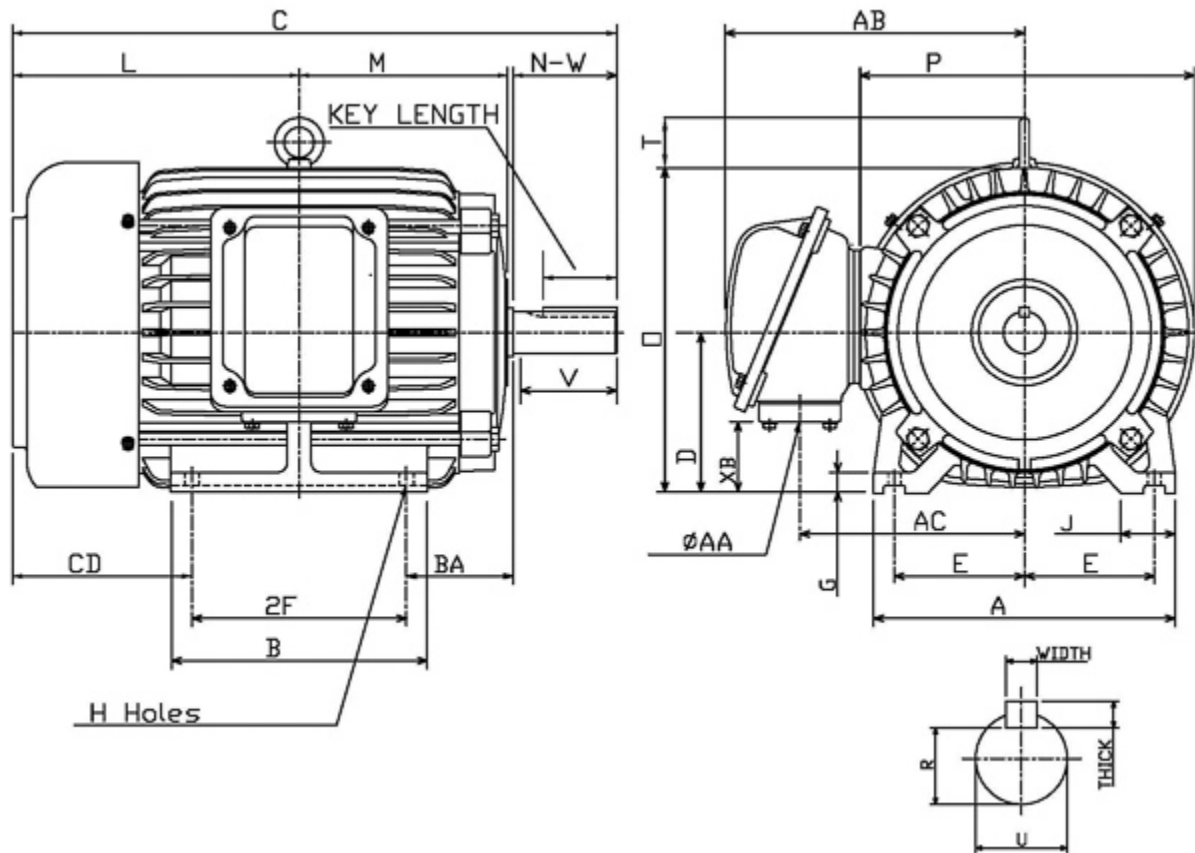

Frame Size	Mounting					A	B	C	CD	D	
	E	2F	2F2	H	BA						
213T	4.25	5.5		0.41	3.5	9.85	6.9	17.98		5.25	
G	J	K	L	M	O	P	T	Key			Keyseat
0.7	1.75		8.35	6.06	10.8	11.1	1.46	Width	Thick	Length	R
								0.312	0.312	2.41	1.201
Terminal Housing			Aux Box			C/D Flange					
AA	AB	AC	XB	AE	AX	BB	AH	AK	BD	AJ	BF
1 NPT	9.78	7.34	2.34								
Shaft Extension			Bearings		Approx. Weight Lbs	SPL dBA/3ft	Ins. Class	S.F.	Drive Method	Dimensions	
N-W	U	V	DE	NDE							
3.38	1.375	3.3	6308ZZ	6306ZZ	165	54	F	1.15	Direct Coupling / Belt Drive	Inches	

Technical Data Sheet

Motor Type: AEHH8N

Catalogue No: PDH00365

Nameplate Information

HP	Pole	RPM	Frame	Voltage	Hz	Phase
3	6	1175	213T	575	60	3
Enclosure	Ins. Class	Service Factor	Time Rating	NEMA Design	Rated Amb.	Rated Altitude
TEFC	F	1.15	Continuous	B	-40 to 40 °C	<3300 ft

Typical Performance

Efficiency (%)				Power Factor (%)		
Full Load		3/4 Load	1/2 Load	Full Load	3/4 Load	1/2 Load
Nom.	Min.					
89.5	87.5	89.5	87.5	78.0	70.5	85.5
Torque				Current (A)		
Full Load (lb-ft)	Locked Rotor (% FLT)	Pull Up (% FLT)	Break Down (% FLT)	No Load	Full Load	Locked Rotor
13.41	210	180	340	1.7	3.2	26
NEMA KVA Code	Inertia (WR ²)			Safe Stall Time (s)		Noise Level Sound Press. dB(A)
	Rotor (lb-ft ²)	NEMA Load (lb-ft ²)	Max. Allowable (lb-ft ²)	Cold	Hot	
K	0.918	44.0	378.0	88	62	54

VFD Duty Information

Speed Range			VFD		S.F.
Constant Torque	Variable Torque	Constant Power	Carrier	Type	
6-60Hz	3-60Hz	60-120Hz	≤ 5 kHz	VPWM or CPWM	1.0 Only

Additional Information

Bearings		Approx. Weight
DE	NDE	lbs
6308ZZ	6306ZZ	165

Hazardous Locations Information

CSA Certified	
Class I, Div 2, Groups B, C & D	
Class I, Zone 2, Groups IIB+H2, IIB & IIA	
Temp Code (Sinewave / VFD)	T3C / T3C

Connection Diagram



3 LEAD		SINGLE VOLTAGE			WYE
VOLTAGE	CONN.	L1	L2	L3	
-	WYE	1	2	3	

WD_3Y

Thermal Limit Curves

Motor Type: AEHH8N		Catalogue No: PDH00365		Family: Optim TEFC	
HP	3	Safe Stall Time		Full Load A	0.0 / 3.2 A
Voltage	0 / 575V 60Hz	Hot	62 s	Locked Rotor A	807 %
RPM	1200	Cold	88 s	Locked Rotor A	0.0 / 26 A

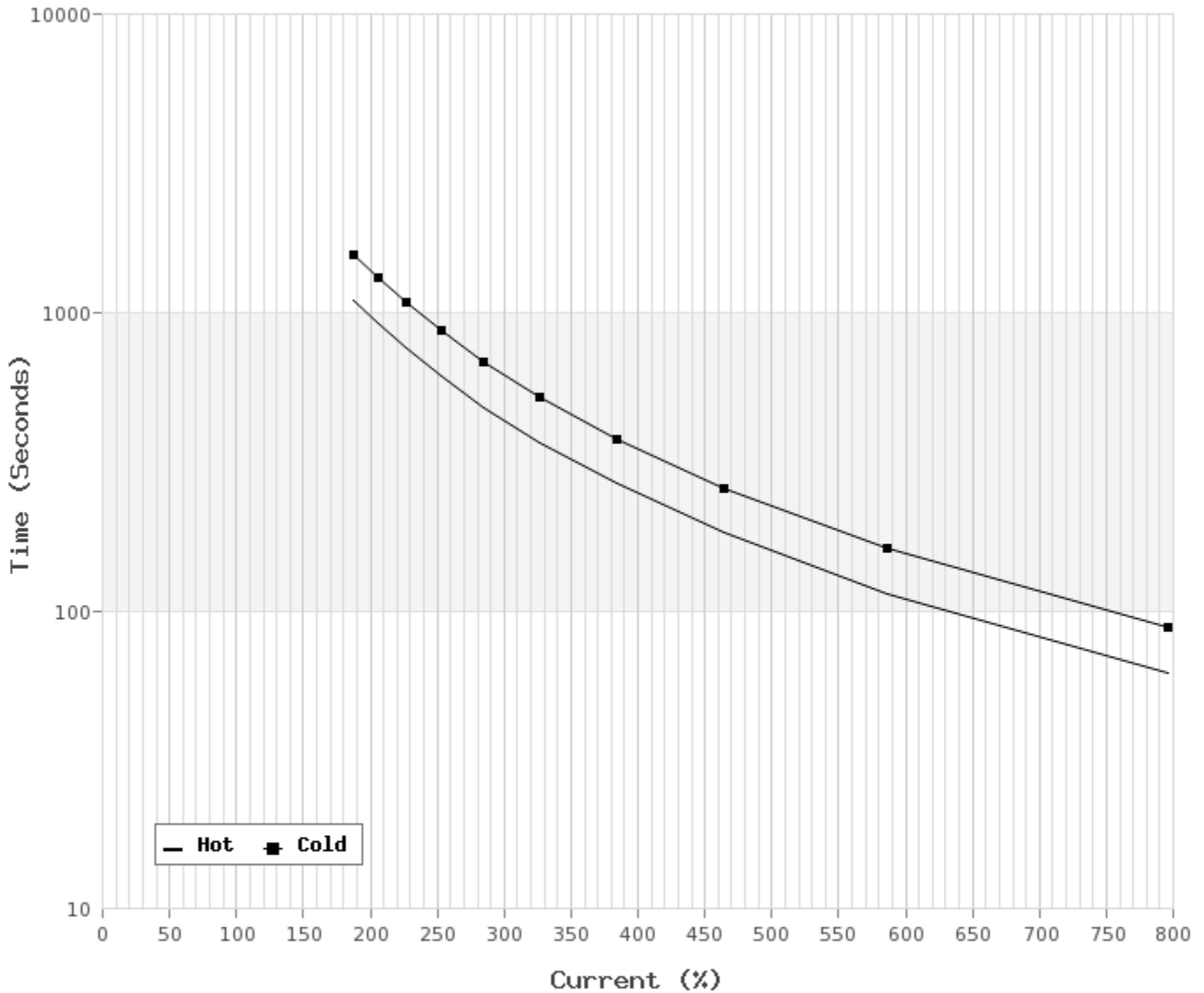

T-N and I-N Curves

Motor Type: AEHH8N		Catalogue No: PDH00365		Family: Optim TEFC	
HP	3	Full Load T	13.41 lb-ft	Full Load A	3.2 A
Voltage	575V 60Hz	Locked Rotor T	210 %	Locked Rotor A	26.0 A
RPM	1200	Pull Up T	180 %	Break Down T	340 %

