

Technical Documentation

**PDX05045**  
**Optim TEFC | AEHH8N**

Date: July 1, 2021

**Dimensional Drawing**

Catalogue	Type	HP	RPM	Voltage	Hz	Frame Size
PDX05045	AEHH8N	50	1800	575	60	326T(X)

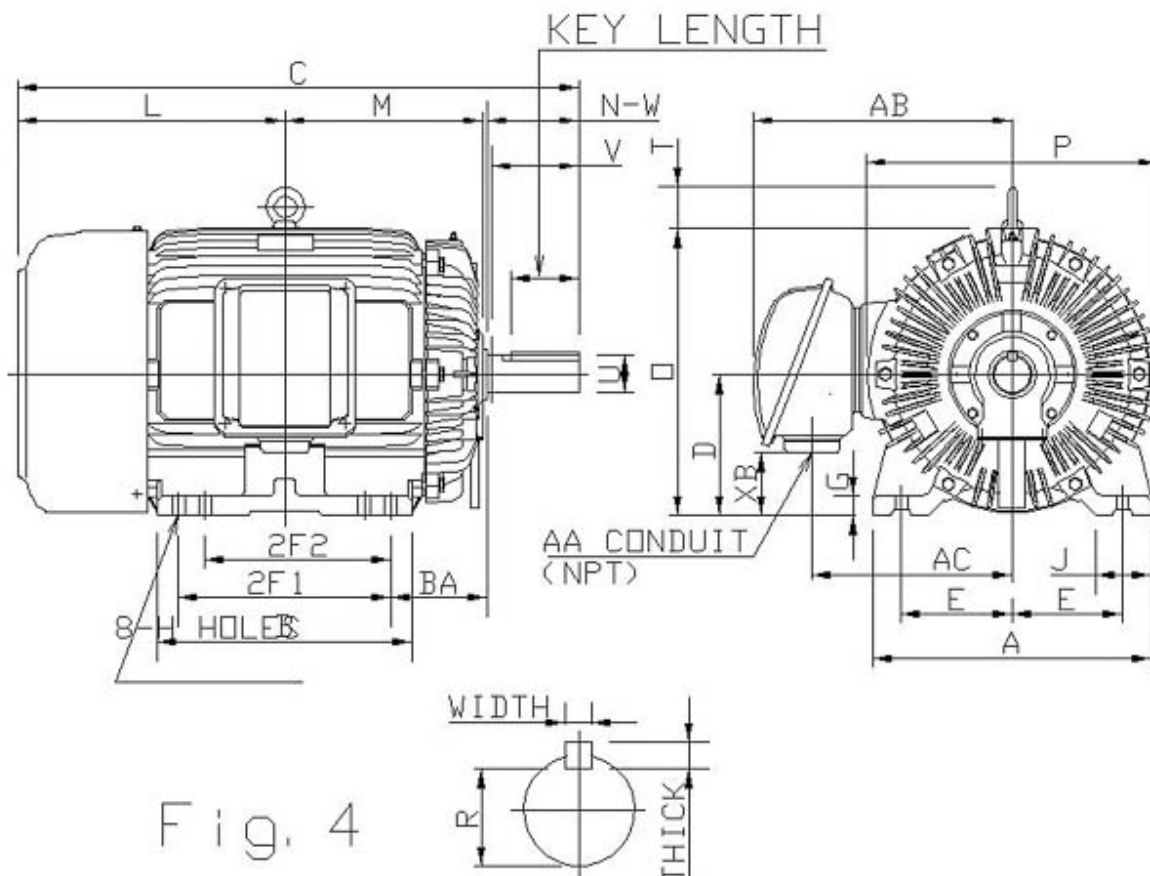

Fig. 4

Mounting					A	B	C	CL1	CL2	D	G
E	2F1	2F2	H	BA							
6.25	12	10.5	0.67	5.25	15.75	14.37	30.99			8	1.1

J	K	L	M	O	P	T
3.15		14.49	10.96	15.5	15.91	2.36

Terminal Housing			
AA	AB	AC	XB
2	16.07	12.2	3.59

Shaft Extension			Key			Keyseat
N-W	U	V	Width	Thick	Length	R
5.25	2.125	5.15	0.5	0.5	3.91	2.201

Bearings		Weight Lbs	Drive Method	Dimensions
DE	NDE			
6312	6310	591	Direct Coupling / Belt Drive	Inches

### Technical Data Sheet

Motor Type: AEHH8N

Catalogue No: PDX05045

#### Nameplate Information

HP	Pole	RPM	Frame	Voltage	Hz	Phase
50	4	1770	326T(X)	575	60	3
Enclosure	Ins. Class	Service Factor	Time Rating	NEMA Design	Rated Amb.	Rated Altitude
TEFC	F	1.15	Continuous	C	-40 to 40 °C	<1000 m

#### Typical Performance

Efficiency (%)				Power Factor (%)		
Full Load		3/4 Load	1/2 Load	Full Load	3/4 Load	1/2 Load
Nom.	Min.					
94.50	93.60	94.50	94.00	85.00	83.00	77.00
Torque				Current (A)		
Full Load (lb-ft)	Locked Rotor (% FLT)	Pull Up (% FLT)	Break Down (% FLT)	No Load	Full Load	Locked Rotor
148.31	230	200	250	14.6	46.6	290.40
NEMA KVA Code	Inertia (WR <sup>2</sup> )			Safe Stall Time (s)		Noise Level Sound Press. dB(A)
	Rotor (lb-ft <sup>2</sup> )	NEMA Load (lb-ft <sup>2</sup> )	Max. Allowable (lb-ft <sup>2</sup> )	Cold	Hot	
G	6.393	39.00	596.00	17	12	76.0

#### VFD Duty Information

Speed Range			VFD		S.F.
Constant Torque	Variable Torque	Constant Power	Carrier	Type	
6-60Hz	3-60Hz	60-90Hz	0	VPWM or CPWM	1.0 Only

#### Hazardous Locations Information

CSA Certified
Class I, Div 2, Groups B, C & D Class I, Zone 2, Groups IIB+H2, IIB & IIA
Temp Code (Sinewave / VFD)      T3 / T3

#### Additional Certifications

Other Certification

#### Additional Information

Bearings		Approx. Weight
DE	NDE	lbs
6312	6310	591

**Nameplate Drawing**

# Optim TEFC

TYPE	AEHH8N	CAT. NO.	PDX05045		
OUTPUT	50 HP 37.30 kW	FRAME	326T(X)	TEFC	
R.P.M.	1770	POLE	4	INS.	F
VOLTS	575	PHASE	3	Hz	60
AMPS	46.6	CODE	G	S.F.	1.15
AMBIENT	40 °C	NOM. EFF. 94.50		MIN. EFF. 93.60	
BEARINGS	6312 / 6310			RATING Cont.	
SER. NO.	TBD	DESIGN	C	WT. 591 LBS	
PWM VFD DUTY	VT	CT	CP	S.F.	
	3-60Hz	6-60Hz	60-90Hz	1.0 Only	

**Connection Diagram**



3 LEAD		SINGLE VOLTAGE			DELTA
VOLTAGE	CONN.	L1	L2	L3	
-	DELTA	1	2	3	

WD\_3D

**Thermal Limit Curves**

Motor Type: AEHH8N		Catalogue No: PDX05045		Family: Optim TEFC	
HP	50	Safe Stall Time		Full Load A	46.6 A
Voltage	575V 60Hz	Hot	12 s	% Inrush	623 %
RPM	1800	Cold	17 s	Locked Rotor A	290.40 A

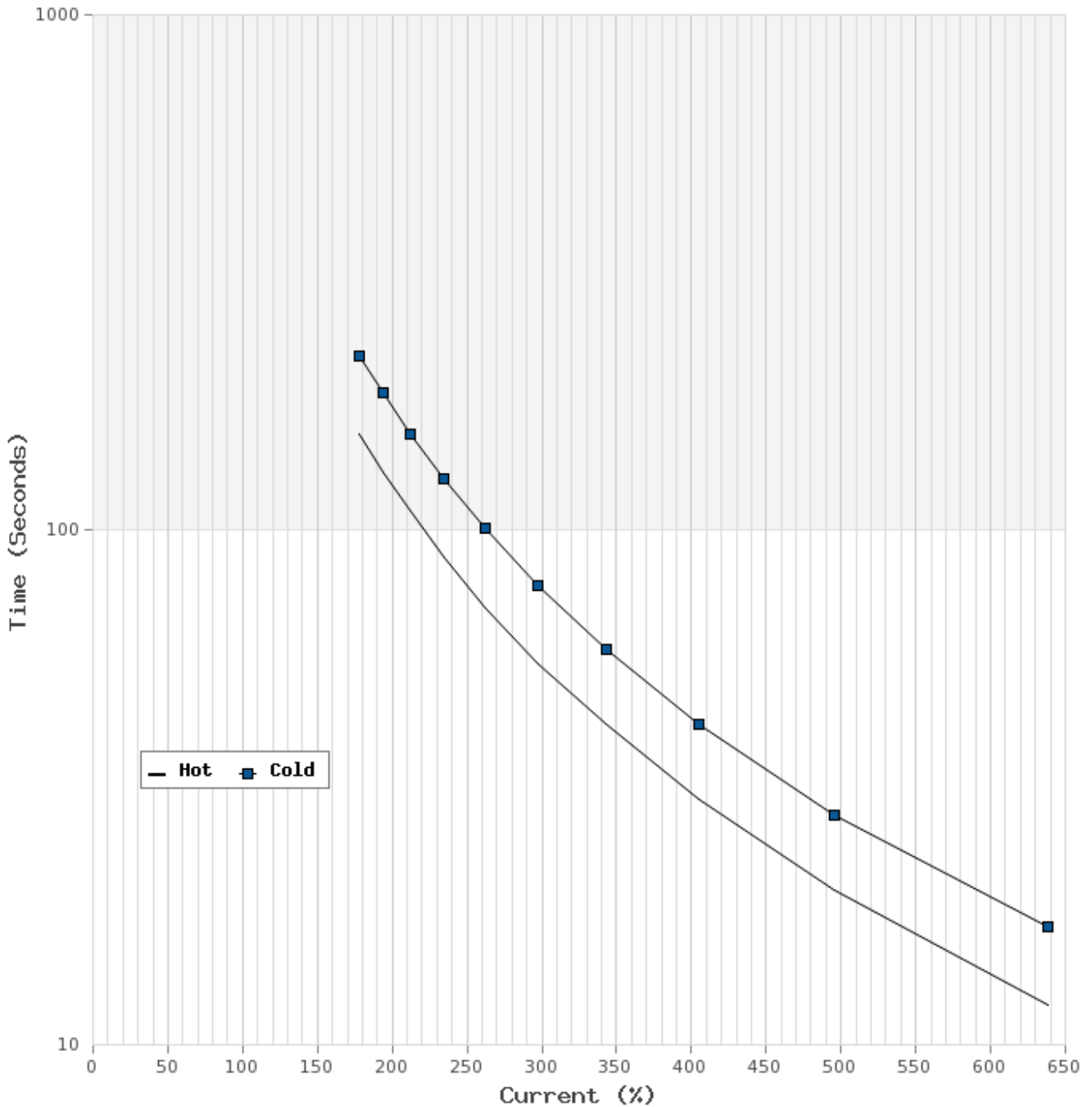

**T-N and I-N Curves**

Motor Type: AEHH8N		Catalogue No: PDX05045		Family: Optim TEFC	
HP	50	Full Load T	148.31 lb-ft	Full Load A	46.6 A
Voltage	575V 60Hz	Locked Rotor T	230 %	Locked Rotor A	290.4 A
RPM	1800	Pull Up T	200 %	Break Down T	250 %

