

Technical Documentation

PDH1/58
Optim TEFC | AEHH8N

Date: November 30, 2016

Dimensional Drawing

Catalogue	Model	HP	Pole	kW	Rating	Voltage	Hz	RPM
PDH1/58	AEHH8N	1.5	8	1.1	Continuous	230 / 460 V	60	900

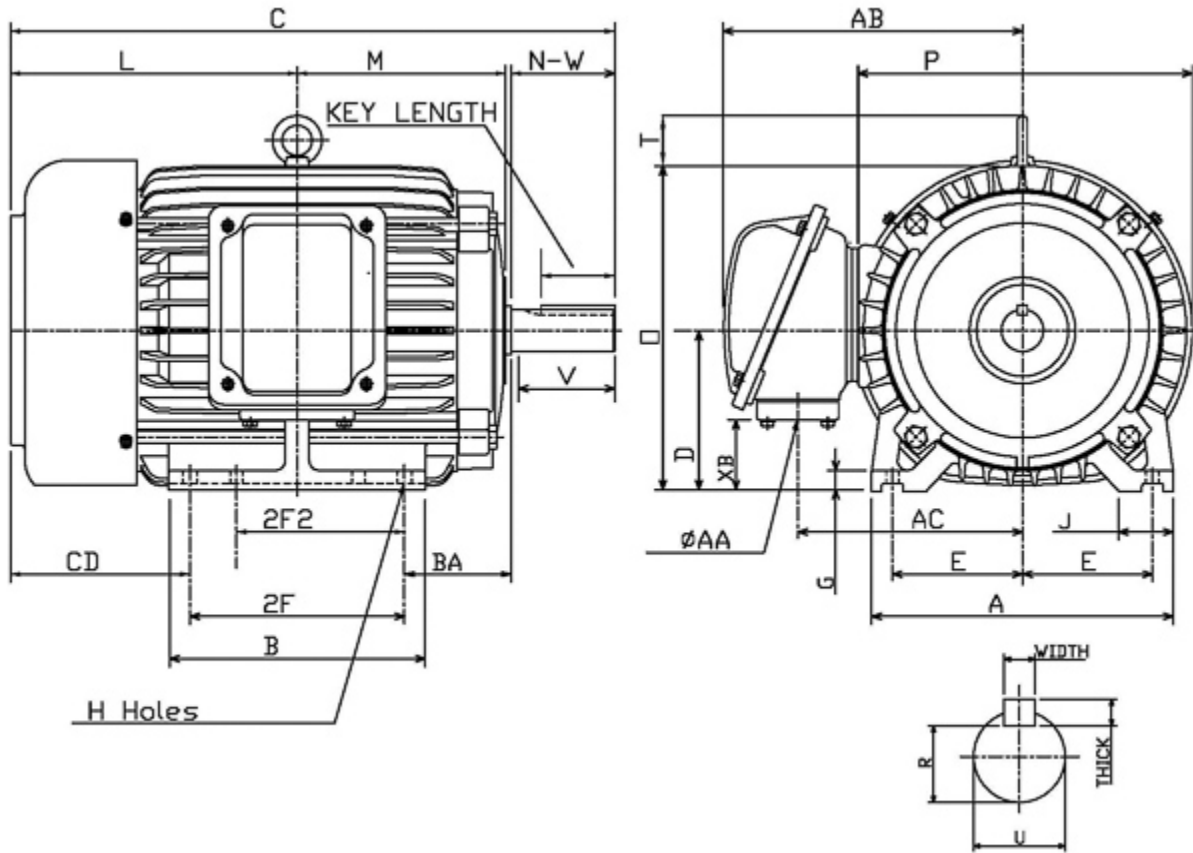

Frame Size	Mounting					A	B	C	CD	D	
	E	2F	2F2	H	BA						
184T	3.75	5.5	4.5	0.41	2.75	8.8	6.9	15.73		4.5	
G	J	K	L	M	O	P	T	Key			Keyseat
0.65	1.75		7.48	5.37	9.31	9.61	1.19	Width	Thick	Length	R
								0.25	0.25	1.78	0.986
Terminal Housing			Aux Box			C/D Flange					
AA	AB	AC	XB	AE	AX	BB	AH	AK	BD	AJ	BF
3/4 NPT	8.31	6.38	1.86								
Shaft Extension			Bearings		Approx. Weight Lbs	SPL dBA/3ft	Ins. Class	S.F.	Drive Method	Dimensions	
N-W	U	V	DE	NDE							
2.75	1.125	2.7	6306ZZ	6306ZZ	92	51	F	1.15	Direct Coupling / Belt Drive	Inches	

Technical Data Sheet

Motor Type: AEHH8N

Catalogue No: PDH1/58

Nameplate Information

HP	Pole	RPM	Frame	Voltage	Hz	Phase
1.5	8	860	184T	230 / 460	60	3
Enclosure	Ins. Class	Service Factor	Time Rating	NEMA Design	Rated Amb.	Rated Altitude
TEFC	F	1.15	Continuous	B	-40 to 40 °C	<3300 ft

Typical Performance

Efficiency (%)				Power Factor (%)		
Full Load		3/4 Load	1/2 Load	Full Load	3/4 Load	1/2 Load
Nom.	Min.					
77.0	74.0	75.5	70.0	60.5	51.5	39.5
Torque				Current (A)		
Full Load (lb-ft)	Locked Rotor (% FLT)	Pull Up (% FLT)	Break Down (% FLT)	No Load	Full Load	Locked Rotor
9.16	185	130	250	5.0 / 2.5	6.0 / 3.0	40 / 20
NEMA KVA Code	Inertia (WR ²)			Safe Stall Time (s)		Noise Level Sound Press. dB(A)
	Rotor (lb-ft ²)	NEMA Load (lb-ft ²)	Max. Allowable (lb-ft ²)	Cold	Hot	
M	0.275	45.0	144.0	60	42	51

VFD Duty Information

Speed Range			VFD		S.F.
Constant Torque	Variable Torque	Constant Power	Carrier	Type	
6-60Hz	3-60Hz	60-120Hz	≤ 5 kHz	VPWM or CPWM	1.0 Only

Additional Information

Bearings		Approx. Weight
DE	NDE	lbs
6306ZZ	6306ZZ	92

Hazardous Locations Information

CSA Certified	
Class I, Div 2, Groups B, C & D	
Class I, Zone 2, Groups IIB+H2, IIB & IIA	
Temp Code (Sinewave / VFD)	T3A / T3A

Connection Diagram

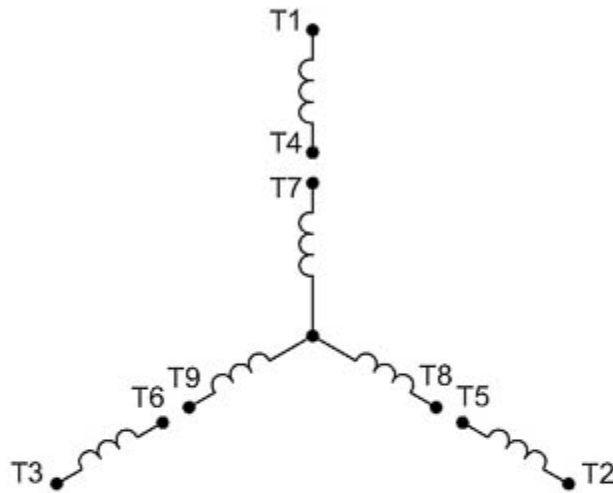

9 LEAD DUAL VOLTAGE WYE					
VOLTAGE	CONN.	L1	L2	L3	JOIN
HIGH	WYE	1	2	3	4&7,5&8,6&9
LOW	2 WYE	1,7	2,8	3,9	4&5&6

WD_9Y

Thermal Limit Curves

Motor Type: AEHH8N		Catalogue No: PDH1/58		Family: Optim TEFC	
HP	1.5	Safe Stall Time		Full Load A	6.0 / 3.0 A
Voltage	230 / 460V 60Hz	Hot	42 s	Locked Rotor A	663 / 664 %
RPM	900	Cold	60 s	Locked Rotor A	40.0 / 20 A

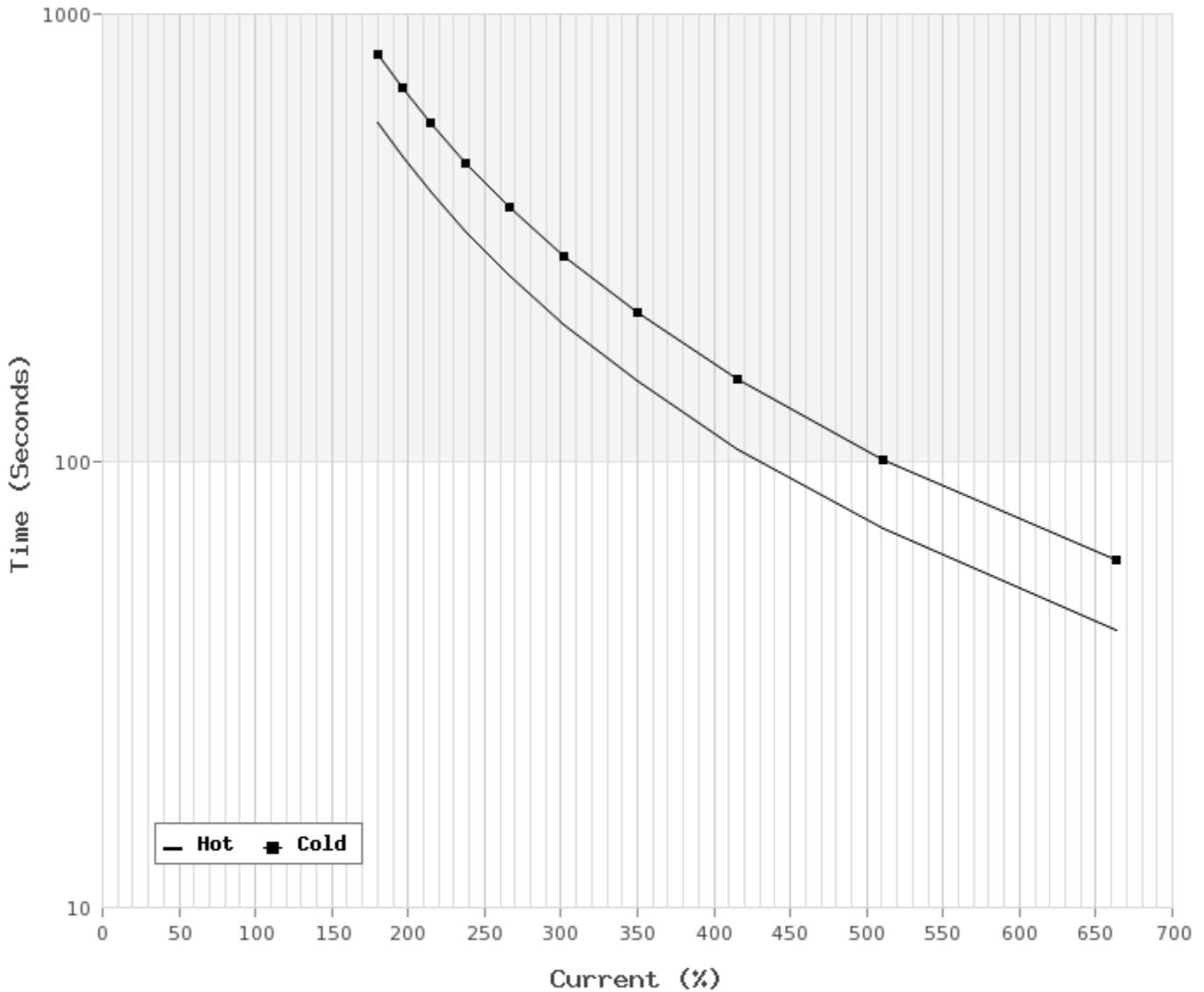

T-N and I-N Curves

Motor Type: AEHH8N		Catalogue No: PDH1/58		Family: Optim TEFC	
HP	1.5	Full Load T	9.16 lb-ft	Full Load A	6.0 / 3.0 A
Voltage	230 / 460V 60Hz	Locked Rotor T	185 %	Locked Rotor A	40.0 / 20.0 A
RPM	900	Pull Up T	130 %	Break Down T	250 %

