

Technical Documentation

# **PDH0028**

## **Optim TEFC | AEHH8N**

Date: November 30, 2016

### Dimensional Drawing

Catalogue	Model	HP	Pole	kW	Rating	Voltage	Hz	RPM
PDH0028	AEHH8N	2	8	1.5	Continuous	230 / 460 V	60	900

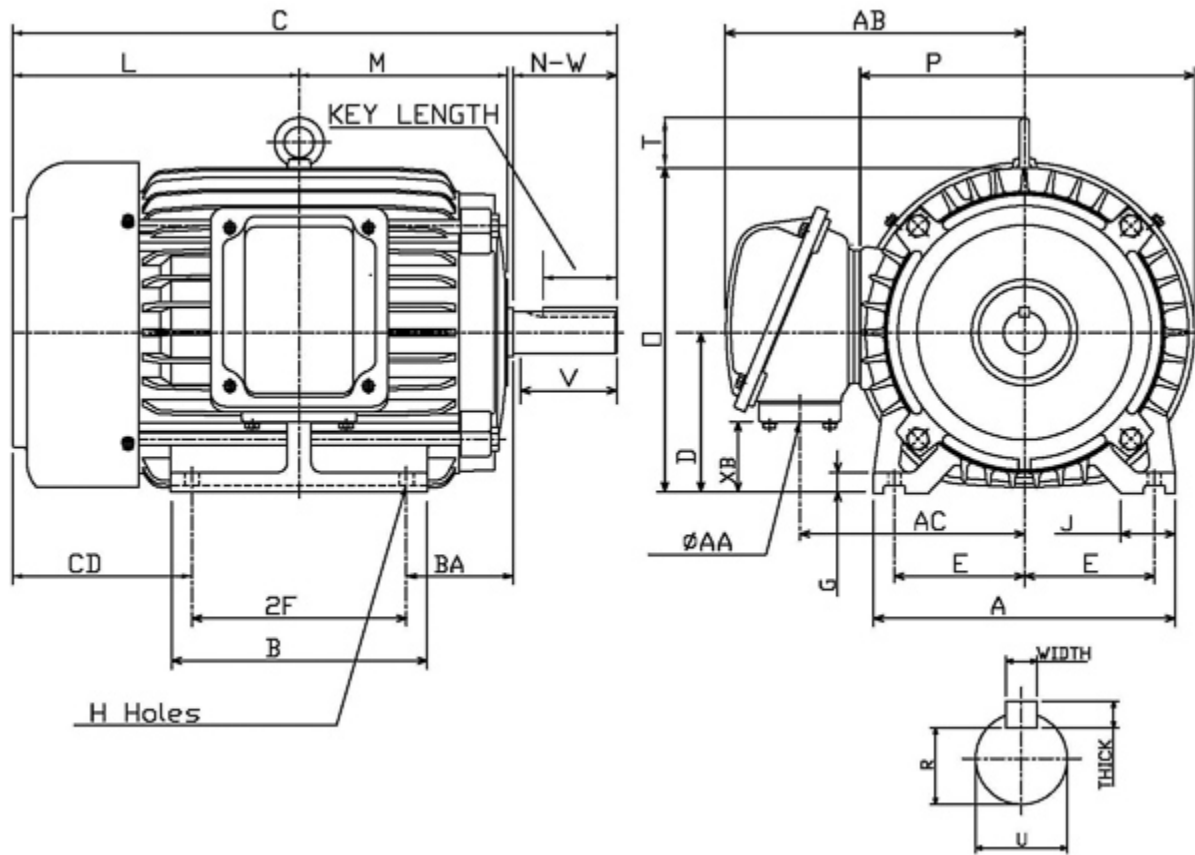

Frame Size	Mounting					A	B	C	CD	D	
	E	2F	2F2	H	BA						
213T	4.25	5.5		0.41	3.5	9.85	6.9	17.98		5.25	
G	J	K	L	M	O	P	T	Key			Keyseat
0.7	1.75		8.35	6.06	10.8	11.1	1.46	Width	Thick	Length	R
								0.312	0.312	2.41	1.201
Terminal Housing			Aux Box			C/D Flange					
AA	AB	AC	XB	AE	AX	BB	AH	AK	BD	AJ	BF
1 NPT	9.78	7.34	2.34								
Shaft Extension			Bearings		Approx. Weight Lbs	SPL dBA/3ft	Ins. Class	S.F.	Drive Method	Dimensions	
N-W	U	V	DE	NDE							
3.38	1.375	3.3	6308ZZ	6306ZZ	134	52	F	1.15	Direct Coupling / Belt Drive	Inches	

### Technical Data Sheet

Motor Type: AEHH8N

Catalogue No: PDH0028

#### Nameplate Information

HP	Pole	RPM	Frame	Voltage	Hz	Phase
2	8	865	213T	230 / 460	60	3
Enclosure	Ins. Class	Service Factor	Time Rating	NEMA Design	Rated Amb.	Rated Altitude
TEFC	F	1.15	Continuous	B	-40 to 40 °C	<3300 ft

#### Typical Performance

Efficiency (%)				Power Factor (%)		
Full Load		3/4 Load	1/2 Load	Full Load	3/4 Load	1/2 Load
Nom.	Min.					
85.5	82.5	84.0	82.5	64.0	55.0	42.5
Torque				Current (A)		
Full Load (lb-ft)	Locked Rotor (% FLT)	Pull Up (% FLT)	Break Down (% FLT)	No Load	Full Load	Locked Rotor
12.14	190	170	275	4.7 / 2.4	6.8 / 3.4	50 / 25
NEMA KVA Code	Inertia (WR <sup>2</sup> )			Safe Stall Time (s)		Noise Level Sound Press. dB(A)
	Rotor (lb-ft <sup>2</sup> )	NEMA Load (lb-ft <sup>2</sup> )	Max. Allowable (lb-ft <sup>2</sup> )	Cold	Hot	
L	0.586	59.0	285.0	66	46	52

#### VFD Duty Information

Speed Range			VFD		S.F.
Constant Torque	Variable Torque	Constant Power	Carrier	Type	
6-60Hz	3-60Hz	60-120Hz	≤ 5 kHz	VPWM or CPWM	1.0 Only

#### Additional Information

Bearings		Approx. Weight
DE	NDE	lbs
6308ZZ	6306ZZ	134

#### Hazardous Locations Information

CSA Certified	
Class I, Div 2, Groups B, C & D	
Class I, Zone 2, Groups IIB+H2, IIB & IIA	
Temp Code (Sinewave / VFD)	T3A / T3A

**Connection Diagram**



9 LEAD DUAL VOLTAGE WYE					
VOLTAGE	CONN.	L1	L2	L3	JOIN
HIGH	WYE	1	2	3	4&7,5&8,6&9
LOW	2 WYE	1,7	2,8	3,9	4&5&6

WD\_9Y

**Thermal Limit Curves**

Motor Type: AEHH8N		Catalogue No: PDH0028		Family: Optim TEFC	
HP	2	Safe Stall Time		Full Load A	6.8 / 3.4 A
Voltage	230 / 460V 60Hz	Hot	46 s	Locked Rotor A	731 / 731 %
RPM	900	Cold	66 s	Locked Rotor A	50.0 / 25 A

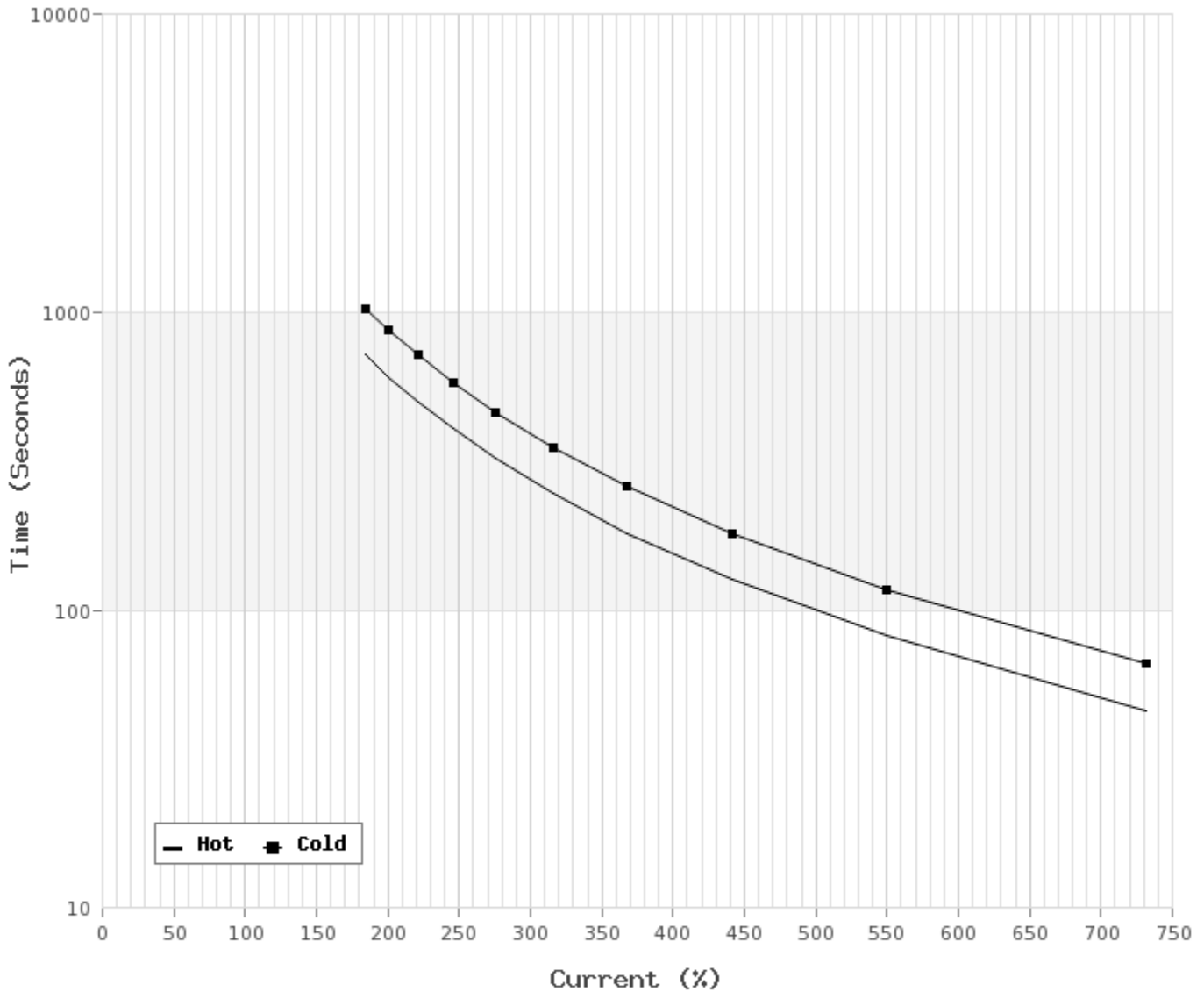

**T-N and I-N Curves**

Motor Type: AEHH8N		Catalogue No: PDH0028		Family: Optim TEFC	
HP	2	Full Load T	12.14 lb-ft	Full Load A	6.8 / 3.4 A
Voltage	230 / 460V 60Hz	Locked Rotor T	190 %	Locked Rotor A	50.0 / 25.0 A
RPM	900	Pull Up T	170 %	Break Down T	275 %

