

Technical Documentation

APH0752

Advantage Plus IEEE Ready | AEHH8R

Date: June 26, 2020

Dimensional Drawing

Catalogue	Model	HP	Pole	kW	Rating	Voltage	Hz	RPM
APH0752	AEHH8R	75	2	56	Continuous	460	60	3600

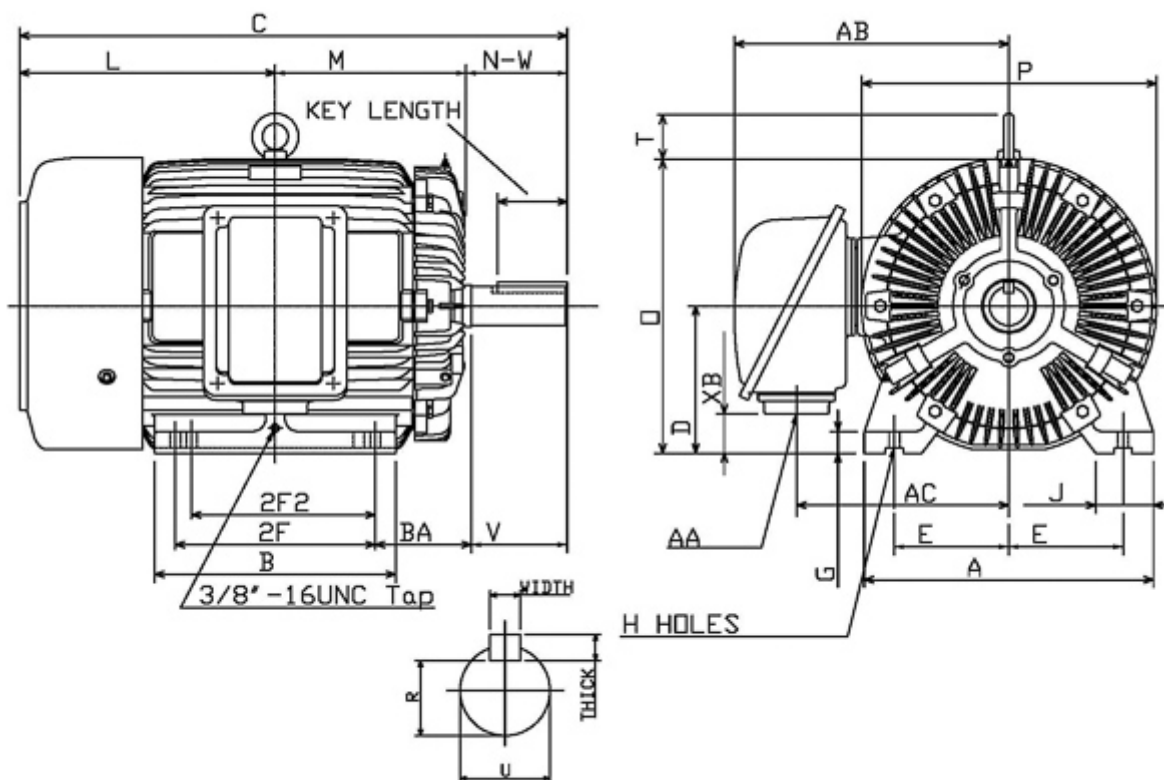

Frame Size	Mounting					A	B	C	CD	D	
	E	2F	2F2	H	BA						
365TS	7	12.25	11.25	0.66	5.88	17.7	14.76	31.42		9	
G	J	K	L	M	O	P	T	Key			Keyseat R
								Width	Thick	Length	
1.32	3.54		15.67	11.59	17.99	18.03	2.76	0.5	0.5	2.03	1.591
Terminal Housing			Aux Box			C/D Flange					
AA	AB	AC	XB	AE	AX	BB	AH	AK	BD	AJ	BF
NPT3"	16.81	12.99	2.39								
Shaft Extension			Bearings		Approx. Weight Lbs	SPL dBA/3ft	Ins. Class	S.F.	Drive Method	Dimensions	
N-W	U	V	DE	NDE							
3.75	1.875	3.65	6312ZC3	6212ZC3	818	83	F	1.15	Direct Coupling	Inches	

 MOTORS (CANADA) INC.	
	Date: June 26, 2020

Technical Data Sheet

Motor Type: AEHH8R	Catalogue No: APH0752
--------------------	-----------------------

Nameplate Information

HP	Pole	RPM	Frame	Voltage	Hz	Phase
75	2	3545	365TS	460	60	3
Enclosure	Ins. Class	Service Factor	Time Rating	NEMA Design	Rated Amb.	Rated Altitude
TEFC	F	1.15	Continuous	B	-40 to 40 °C	<1000 m

Typical Performance

Efficiency (%)				Power Factor (%)		
Full Load		3/4 Load	1/2 Load	Full Load	3/4 Load	1/2 Load
Nom.	Min.					
94.5	93.6	95.0	95.0	93.0	92.5	89.0
Torque				Current (A)		
Full Load (lb-ft)	Locked Rotor (% FLT)	Pull Up (% FLT)	Break Down (% FLT)	No Load	Full Load	Locked Rotor
110.80	145	130	250	14.8	79.9	543
NEMA KVA Code	Inertia (WR ²)			Safe Stall Time (s)		Noise Level Sound Press. dB(A)
	Rotor (lb-ft ²)	NEMA Load (lb-ft ²)	Max. Allowable (lb-ft ²)	Cold	Hot	
G	9.056	71.00	164.00	17	12	83

VFD Duty Information

Speed Range			VFD		S.F.
Constant Torque	Variable Torque	Constant Power	Carrier	Type	
6-60Hz	3-60Hz	60-60Hz	≤ 5 kHz	VPWM or CPWM	1.0 Only

Hazardous Locations Information

CSA Certified
Class I, Div 2, Groups B, C & D Class I, Zone 2, Groups IIB+H2, IIB & IIA
Temp Code (Sinewave / VFD)
T3C / T3

Additional Certifications

Other Certification
Class II, Div 2, Groups F & G

Additional Information

Bearings		Approx. Weight
DE	NDE	lbs
6312ZC3	6212ZC3	818

Nameplate Drawing

Advantage Plus IEEE Ready

TYPE	AEHH8R	CAT. NO.	APH0752		
OUTPUT	75 HP 56 kW	FRAME	365TS	TEFC	
R.P.M.	3545	POLE	2	INS.	F
VOLTS	460	PHASE	3	Hz	60
AMPS	79.9	CODE	G	S.F.	1.15
AMBIENT	40 °C	NOM. EFF. 94.5		MIN. EFF. 93.6	
BEARINGS	6312ZC3 / 6212ZC3			RATING Cont.	
SER. NO.	TBD	DESIGN	B	WT. 818 LBS	
PWM VFD DUTY	VT	CT	CP	S.F.	
	3-60Hz	6-60Hz	60-60Hz	1.0 Only	

Connection Diagram



3 LEAD		SINGLE VOLTAGE			DELTA
VOLTAGE	CONN.	L1	L2	L3	
-	DELTA	1	2	3	

WD_3D

Thermal Limit Curves

Motor Type: AEHH8R		Catalogue No: APH0752		Family: Advantage Plus IEEE Ready	
HP	75	Safe Stall Time		Full Load A	79.9 A
Voltage	460V 60Hz	Hot	12 s	% Inrush	680 %
RPM	3600	Cold	17 s	Locked Rotor A	543 A

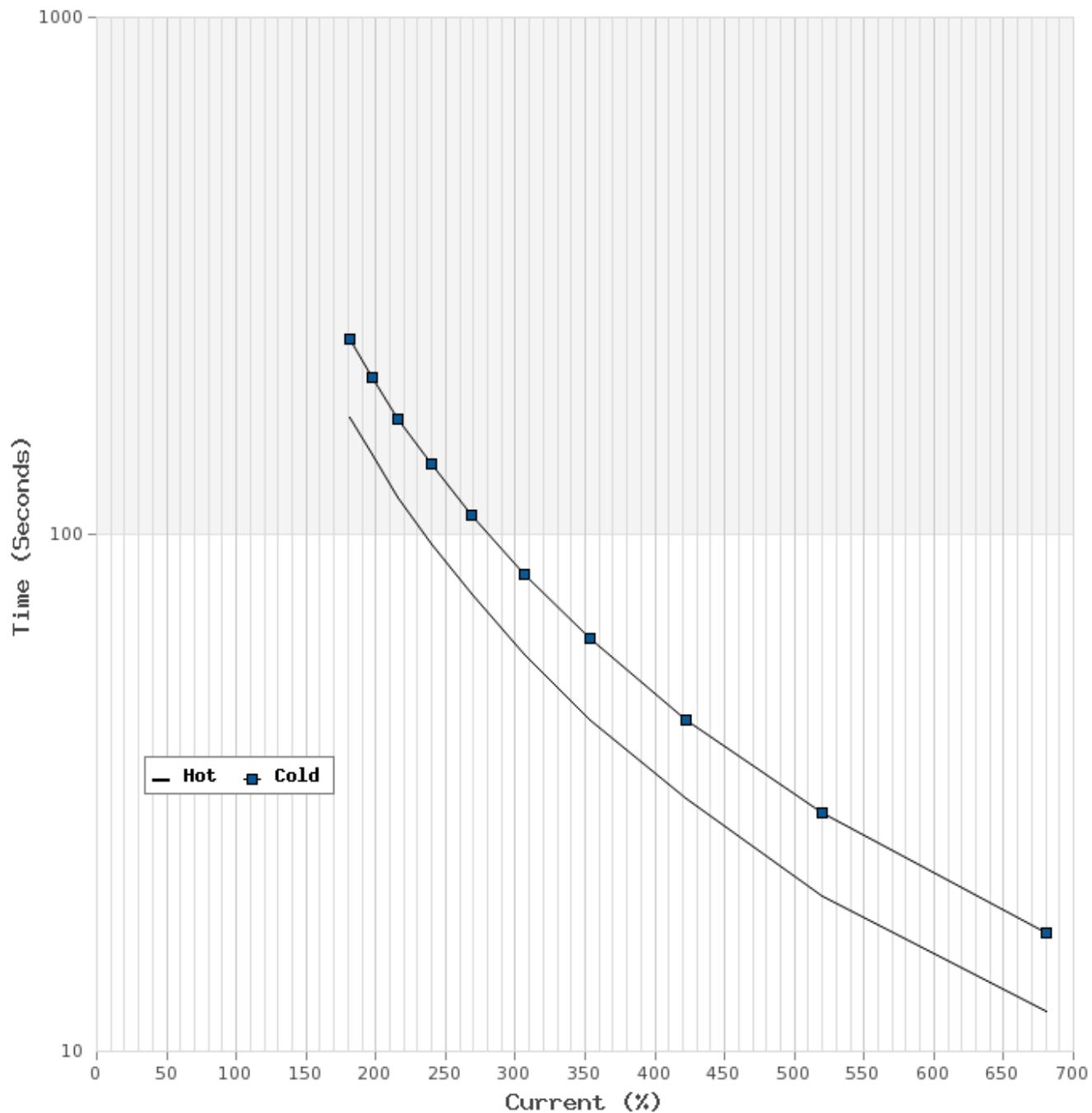

T-N and I-N Curves

Motor Type: AEHH8R		Catalogue No: APH0752		Family: Advantage Plus IEEE Ready	
HP	75	Full Load T	110.80 lb-ft	Full Load A	79.9 A
Voltage	460V 60Hz	Locked Rotor T	145 %	Locked Rotor A	543.0 A
RPM	3600	Pull Up T	130 %	Break Down T	250 %

