

Technical Documentation

APH02045-841
Advantage Plus IEEE 841 | AEHH8B

Date: June 29, 2020

Dimensional Drawing

Catalogue	Model	HP	Pole	kW	Rating	Voltage	Hz	RPM
APH02045-841	AEHH8B	20	4	15	Continuous	575	60	1800

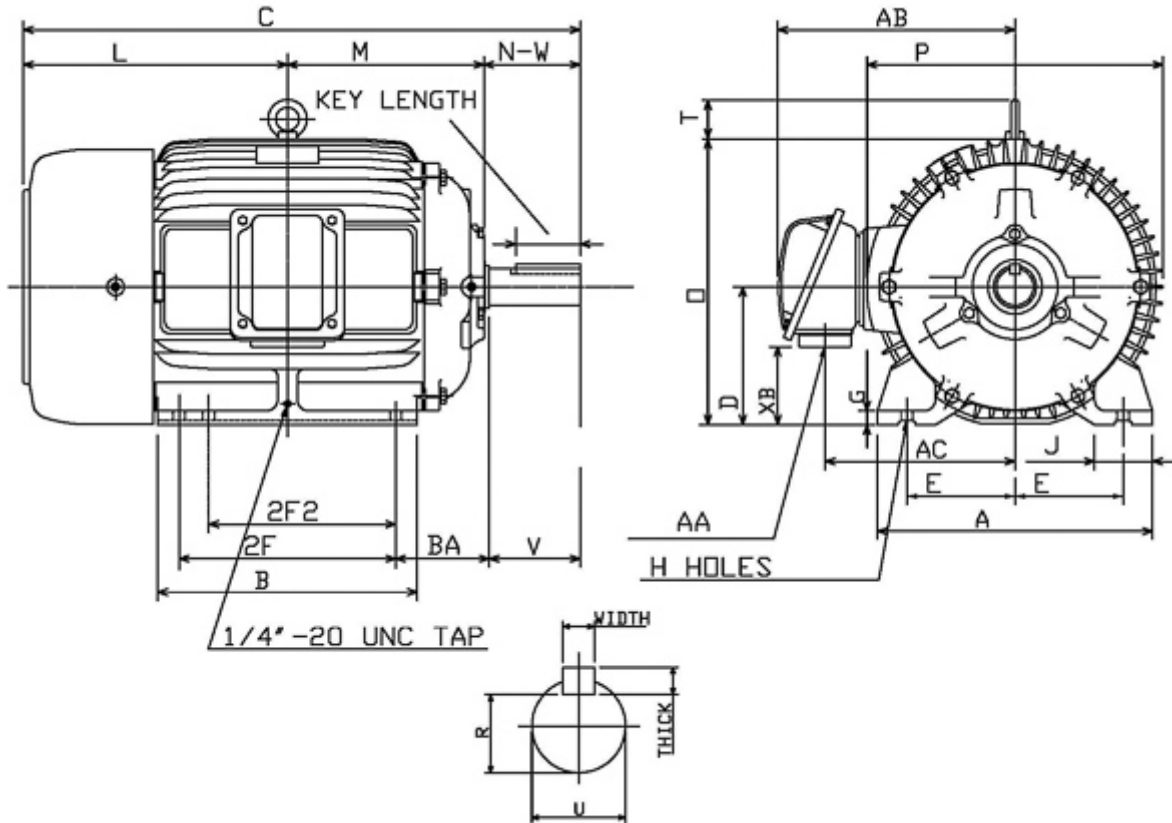

Frame Size	Mounting					A	B	C	CD	D	
	E	2F	2F2	H	BA						
256T	5	10	8.25	0.53	4.25	11.81	11.81	25.52		6.25	
G	J	K	L	M	O	P	T	Key			Keyseat
0.66	1.95		12.27	8.93	12.8	13.15	2.01	Width	Thick	Length	R
								0.375	0.375	2.91	1.416
Terminal Housing			Aux Box			C/D Flange					
AA	AB	AC	XB	AE	AX	BB	AH	AK	BD	AJ	BF
NPT11/4	11.3	8.86	3.22								
Shaft Extension			Bearings		Approx. Weight Lbs	SPL dBA/3ft	Ins. Class	S.F.	Drive Method	Dimensions	
N-W	U	V	DE	NDE							
4	1.625	3.9	6309ZC3	6307ZC3	374	65	F	1.15	Direct Coupling / Belt Drive	Inches	

	
	Date: June 29, 2020

Technical Data Sheet

Motor Type: AEHH8B	Catalogue No: APH02045-841
--------------------	----------------------------

Nameplate Information

HP	Pole	RPM	Frame	Voltage	Hz	Phase
20	4	1760	256T	575	60	3
Enclosure	Ins. Class	Service Factor	Time Rating	NEMA Design	Rated Amb.	Rated Altitude
TEFC	F	1.15	Continuous	B	-40 to 40 °C	<1000 m

Typical Performance

Efficiency (%)				Power Factor (%)		
Full Load		3/4 Load	1/2 Load	Full Load	3/4 Load	1/2 Load
Nom.	Min.					
93.0	91.7	92.4	92.4	87.5	84.5	78.5
Torque				Current (A)		
Full Load (lb-ft)	Locked Rotor (% FLT)	Pull Up (% FLT)	Break Down (% FLT)	No Load	Full Load	Locked Rotor
59.66	200	145	240	5.9	18.4	116
NEMA KVA Code	Inertia (WR ²)			Safe Stall Time (s)		Noise Level Sound Press. dB(A)
	Rotor (lb-ft ²)	NEMA Load (lb-ft ²)	Max. Allowable (lb-ft ²)	Cold	Hot	
G	2.871	99.00	234.00	39	27	65

VFD Duty Information

Speed Range			VFD		S.F.
Constant Torque	Variable Torque	Constant Power	Carrier	Type	
6-60Hz	3-60Hz	60-120Hz	≤ 5 kHz	VPWM or CPWM	1.0 Only

Hazardous Locations Information

CSA Certified
Class I, Div 2, Groups B, C & D Class I, Zone 2, Groups IIB+H2, IIB & IIA
Temp Code (Sinewave / VFD)
T3C / T3B

Additional Certifications

Other Certification

Additional Information

Bearings		Approx. Weight
DE	NDE	lbs
6309ZC3	6307ZC3	374

Nameplate Drawing

Advantage Plus IEEE 841

TYPE	AEHH8B	CAT. NO.	APH02045-841		
OUTPUT	20 HP 15 kW	FRAME	256T	TEFC	
R.P.M.	1760	POLE	4	INS.	F
VOLTS	575	PHASE	3	Hz	60
AMPS	18.4	CODE	G	S.F.	1.15
AMBIENT	40 °C	NOM. EFF. 93.0		MIN. EFF. 91.7	
BEARINGS	6309ZC3 / 6307ZC3			RATING Cont.	
SER. NO.	TBD	DESIGN	B	WT. 374 LBS	
PWM VFD DUTY	VT	CT	CP	S.F.	
	3-60Hz	6-60Hz	60-120Hz	1.0 Only	

Connection Diagram



3 LEAD		SINGLE VOLTAGE			DELTA
VOLTAGE	CONN.	L1	L2	L3	
-	DELTA	1	2	3	

WD_3D

Thermal Limit Curves

Motor Type: AEHH8B		Catalogue No: APH02045-841		Family: Advantage Plus IEEE 841	
HP	20	Safe Stall Time		Full Load A	18.4 A
Voltage	575V 60Hz	Hot	27 s	% Inrush	630 %
RPM	1800	Cold	39 s	Locked Rotor A	116 A

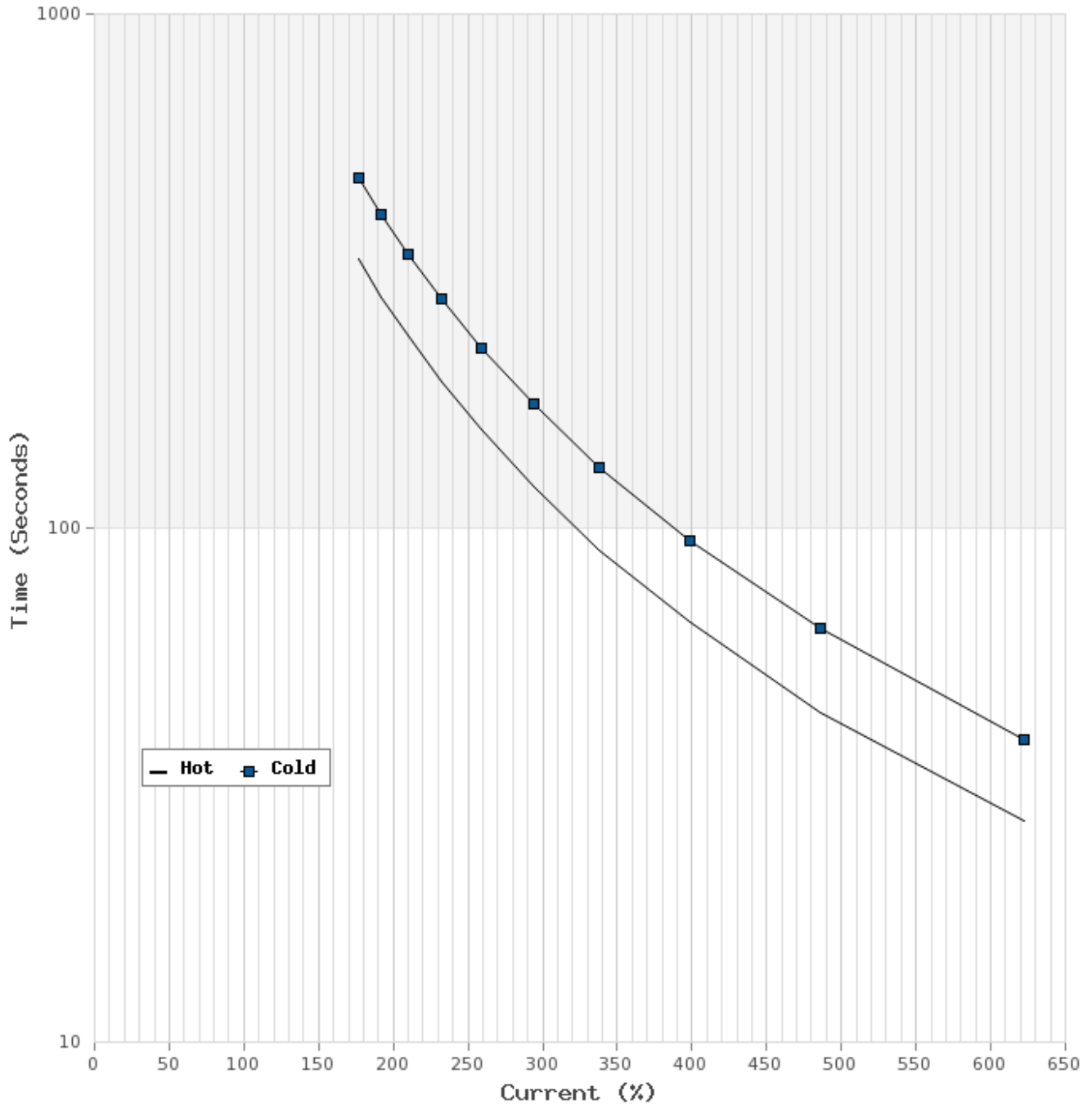

T-N and I-N Curves

Motor Type: AEHH8B		Catalogue No: APH02045-841		Family: Advantage Plus IEEE 841	
HP	20	Full Load T	59.66 lb-ft	Full Load A	18.4 A
Voltage	575V 60Hz	Locked Rotor T	200 %	Locked Rotor A	116.0 A
RPM	1800	Pull Up T	145 %	Break Down T	240 %

