

Technical Documentation

PDH0752C

Optim TEFC | AEHH8N

Date: November 30, 2016

Dimensional Drawing

Catalogue	Model	HP	Pole	kW	Rating	Voltage	Hz	RPM
PDH0752C	AEHH8N	75	2	56	Continuous	230 / 460 V	60	3600

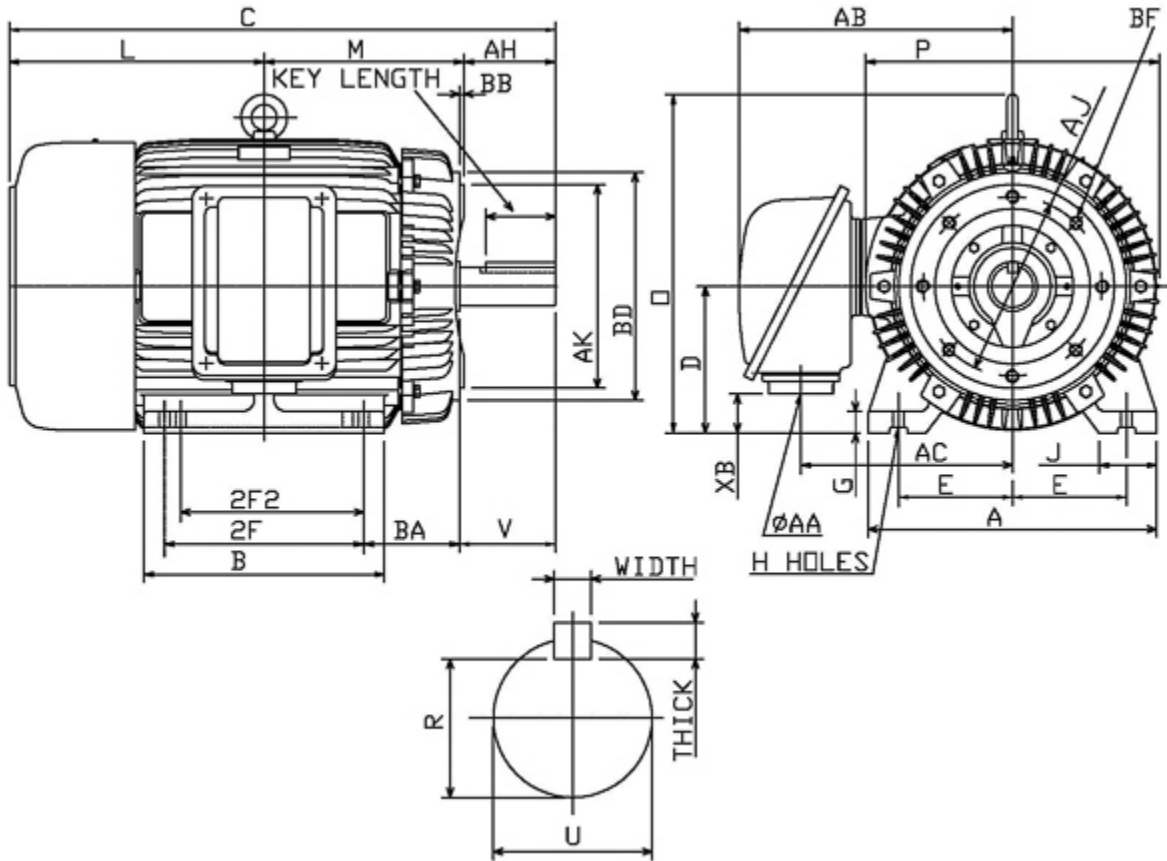

Frame Size	Mounting					A	B	C	CD	D	
	E	2F	2F2	H	BA						
365TSC	7	12.25	11.25	0.66	5.88	17.7	14.75	31.42		9	
G	J	K	L	M	O	P	T	Key			Keyseat
1.3	3.55		15.67	11.79	18.02	18.03	2.76	Width	Thick	Length	R
								0.5	0.5	2.03	1.591
Terminal Housing				Aux Box		C/D Flange					
AA	AB	AC	XB	AE	AX	BB	AH	AK	BD	AJ	BF
3 NPT	16.81	13	2.39			0.25	3.5	12.5	14	11	5/8-11UNC
Shaft Extension			Bearings		Approx. Weight Lbs	SPL dBA/3ft	Ins. Class	S.F.	Drive Method	Dimensions	
N-W	U	V	DE	NDE							
3.75	1.875	3.65	6312C3	6212C3	937	83	F	1.15	Direct Coupling	Inches	

Technical Data Sheet

Motor Type: AEHH8N

Catalogue No: PDH0752C

Nameplate Information

HP	Pole	RPM	Frame	Voltage	Hz	Phase
75	2	3545	365TSC	230 / 460	60	3
Enclosure	Ins. Class	Service Factor	Time Rating	NEMA Design	Rated Amb.	Rated Altitude
TEFC	F	1.15	Continuous	B	-40 to 40 °C	<3300 ft

Typical Performance

Efficiency (%)				Power Factor (%)		
Full Load		3/4 Load	1/2 Load	Full Load	3/4 Load	1/2 Load
Nom.	Min.					
94.5	93.6	95.0	95.0	93.0	92.5	89.0
Torque				Current (A)		
Full Load (lb-ft)	Locked Rotor (% FLT)	Pull Up (% FLT)	Break Down (% FLT)	No Load	Full Load	Locked Rotor
110.80	145	130	250	29.6 / 14.8	159.8 / 79.9	1086 / 543
NEMA KVA Code	Inertia (WR ²)			Safe Stall Time (s)		Noise Level Sound Press. dB(A)
	Rotor (lb-ft ²)	NEMA Load (lb-ft ²)	Max. Allowable (lb-ft ²)	Cold	Hot	
G	9.056	71.0	164.0	17	12	83

VFD Duty Information

Speed Range			VFD		S.F.
Constant Torque	Variable Torque	Constant Power	Carrier	Type	
6-60Hz	3-60Hz	60-60Hz	≤ 5 kHz	VPWM or CPWM	1.0 Only

Additional Information

Bearings		Approx. Weight
DE	NDE	lbs
6312C3	6212C3	937

Hazardous Locations Information

CSA Certified	
Class I, Div 2, Groups B, C & D Class I, Zone 2, Groups IIB+H2, IIB & IIA	
Temp Code (Sinewave / VFD)	T3C / T3

Connection Diagram



12 LEAD DUAL VOLTAGE WYE/DELTA						
VOLTAGE	CONNECTION		L1	L2	L3	JOIN
HIGH	START	WYE	1	2	3	4&7,5&8,6&9 10&11&12
	RUN	DELTA	1,12	2,10	3,11	4&7,5&8,6&9
LOW	START	2 WYE	1,7	2,8	3,9	4&5&6 10&11&12
	RUN	2 DELTA	1,6,7 12	2,4,8 10	3,5,9 11	

WD_12YD

Thermal Limit Curves

Motor Type: AEHH8N		Catalogue No: PDH0752C		Family: Optim TEFC	
HP	75	Safe Stall Time		Full Load A	159.8 / 79.9 A
Voltage	230 / 460V 60Hz	Hot	12 s	Locked Rotor A	680 / 680 %
RPM	3600	Cold	17 s	Locked Rotor A	1,086.0 / 543 A

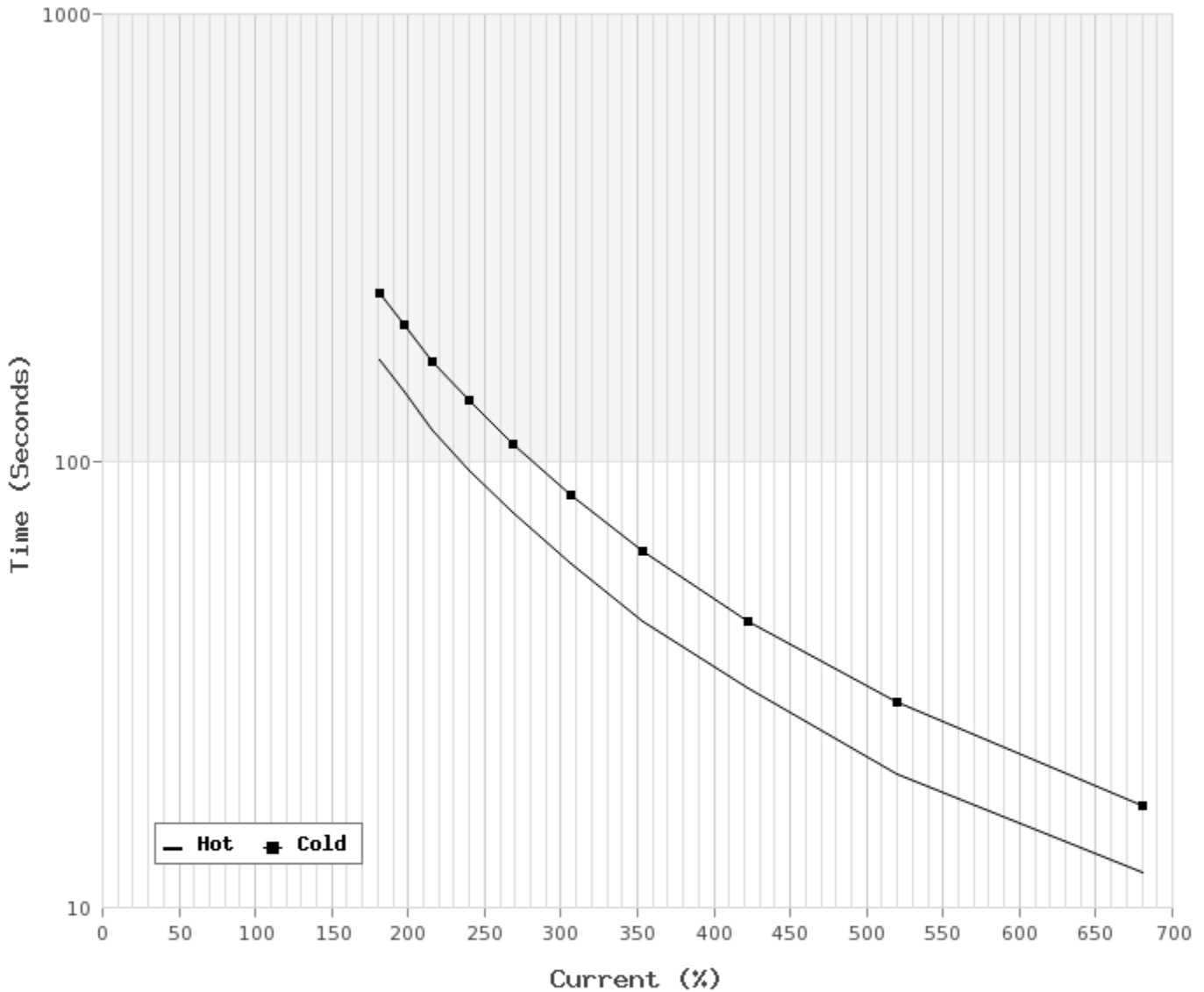

T-N and I-N Curves

Motor Type: AEHH8N		Catalogue No: PDH0752C		Family: Optim TEFC	
HP	75	Full Load T	110.80 lb-ft	Full Load A	159.8 / 79.9 A
Voltage	230 / 460V 60Hz	Locked Rotor T	145 %	Locked Rotor A	1,086.0 / 543.0 A
RPM	3600	Pull Up T	130 %	Break Down T	250 %

