

Technical Documentation

APH15065-841
Advantage Plus IEEE 841 | AEHH8B

Date: June 29, 2020

Dimensional Drawing

Catalogue	Model	HP	Pole	kW	Rating	Voltage	Hz	RPM
APH15065-841	AEHH8B	150	6	112	Continuous	575	60	1200

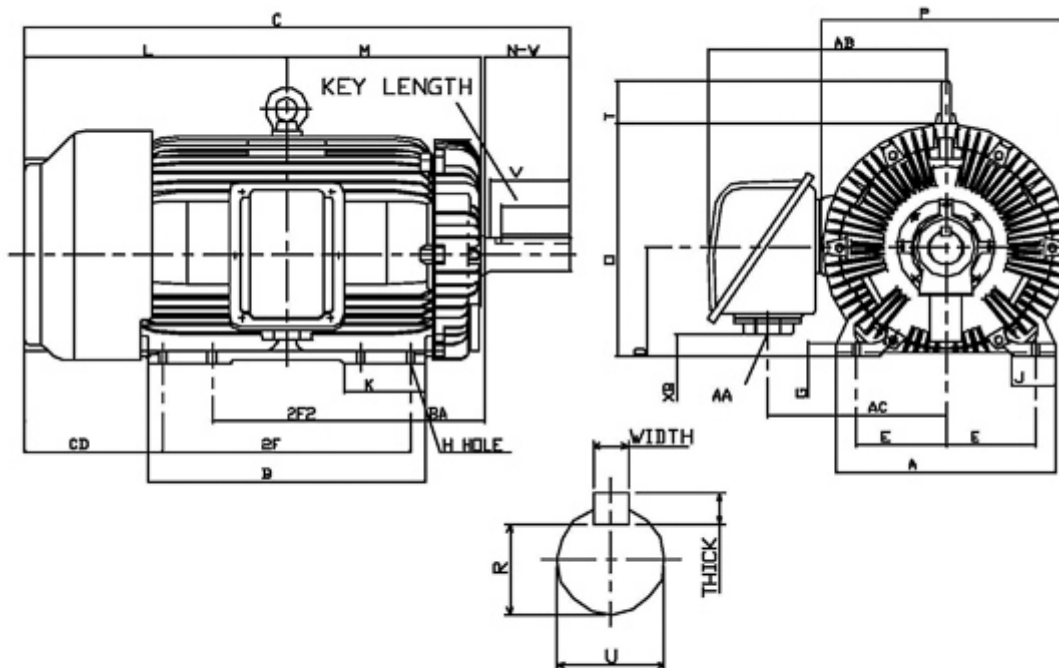

Frame Size	Mounting					A	B	C	CD	D	
	E	2F	2F2	H	BA						
447T	9	20	16.5	0.81	7.5	22.05	23.25	49.9	13.9	11	
G	J	K	L	M	O	P	T	Key			Keyseat
1.4	4.35	6.7	23.9	17.15	23.55	24.75	7.33	Width	Thick	Length	R
								0.875	0.875	6.91	2.88
Terminal Housing			Aux Box			C/D Flange					
AA	AB	AC	XB	AE	AX	BB	AH	AK	BD	AJ	BF
NPT3"	24	17.9	2.4								
Shaft Extension			Bearings		Approx. Weight Lbs	SPL dBA/3ft	Ins. Class	S.F.	Drive Method	Dimensions	
N-W	U	V	DE	NDE							
8.5	3.375	8	6320C3	6316C3	2200	79	F	1.15	Direct Coupling / Belt Drive	Inches	

	
	Date: June 29, 2020

Technical Data Sheet

Motor Type: AEHH8B	Catalogue No: APH15065-841
--------------------	----------------------------

Nameplate Information

HP	Pole	RPM	Frame	Voltage	Hz	Phase
150	6	1186	447T	575	60	3
Enclosure	Ins. Class	Service Factor	Time Rating	NEMA Design	Rated Amb.	Rated Altitude
TEFC	F	1.15	Continuous	B	-40 to 40 °C	<1000 m

Typical Performance

Efficiency (%)				Power Factor (%)		
Full Load		3/4 Load	1/2 Load	Full Load	3/4 Load	1/2 Load
Nom.	Min.					
95.8	95.0	95.4	94.5	83.5	81.0	74.0
Torque				Current (A)		
Full Load (lb-ft)	Locked Rotor (% FLT)	Pull Up (% FLT)	Break Down (% FLT)	No Load	Full Load	Locked Rotor
664.00	135	105	220	40.3	140.5	868
NEMA KVA Code	Inertia (WR ²)			Safe Stall Time (s)		Noise Level Sound Press. dB(A)
	Rotor (lb-ft ²)	NEMA Load (lb-ft ²)	Max. Allowable (lb-ft ²)	Cold	Hot	
G	103.000	1719.00	4298.00	19	13	79

VFD Duty Information

Speed Range			VFD		S.F.
Constant Torque	Variable Torque	Constant Power	Carrier	Type	
12-60Hz	3-60Hz	60-90Hz	≤ 5 kHz	VPWM or CPWM	1.0 Only

Hazardous Locations Information

CSA Certified	
Class I, Div 2, Groups B, C & D Class I, Zone 2, Groups IIB+H2, IIB & IIA	
Temp Code (Sinewave / VFD)	T3C / T3

Additional Certifications

Other Certification

Additional Information

Bearings		Approx. Weight
DE	NDE	lbs
6320C3	6316C3	2200

Nameplate Drawing

Advantage Plus IEEE 841

TYPE	AEHH8B		CAT. NO.	APH15065-841		
OUTPUT	150 HP 112 kW		FRAME	447T	TEFC	
R.P.M.	1186		POLE	6	INS.	F
VOLTS	575		PHASE	3	Hz	60
AMPS	140.5		CODE	G	S.F.	1.15
AMBIENT	40 °C		NOM. EFF. 95.8		MIN. EFF. 95.0	
BEARINGS	6320C3 / 6316C3				RATING Cont.	
SER. NO.	TBD		DESIGN	B	WT. 2200 LBS	
PWM VFD DUTY	VT	CT	CP		S.F.	
	3-60Hz	12-60Hz	60-90Hz		1.0 Only	

Connection Diagram



3 LEAD		SINGLE VOLTAGE			DELTA
VOLTAGE	CONN.	L1	L2	L3	
-	DELTA	1	2	3	

WD_3D

Thermal Limit Curves

Motor Type: AEHH8B		Catalogue No: APH15065-841		Family: Advantage Plus IEEE 841	
HP	150	Safe Stall Time		Full Load A	140.5 A
Voltage	575V 60Hz	Hot	13 s	% Inrush	618 %
RPM	1200	Cold	19 s	Locked Rotor A	868 A

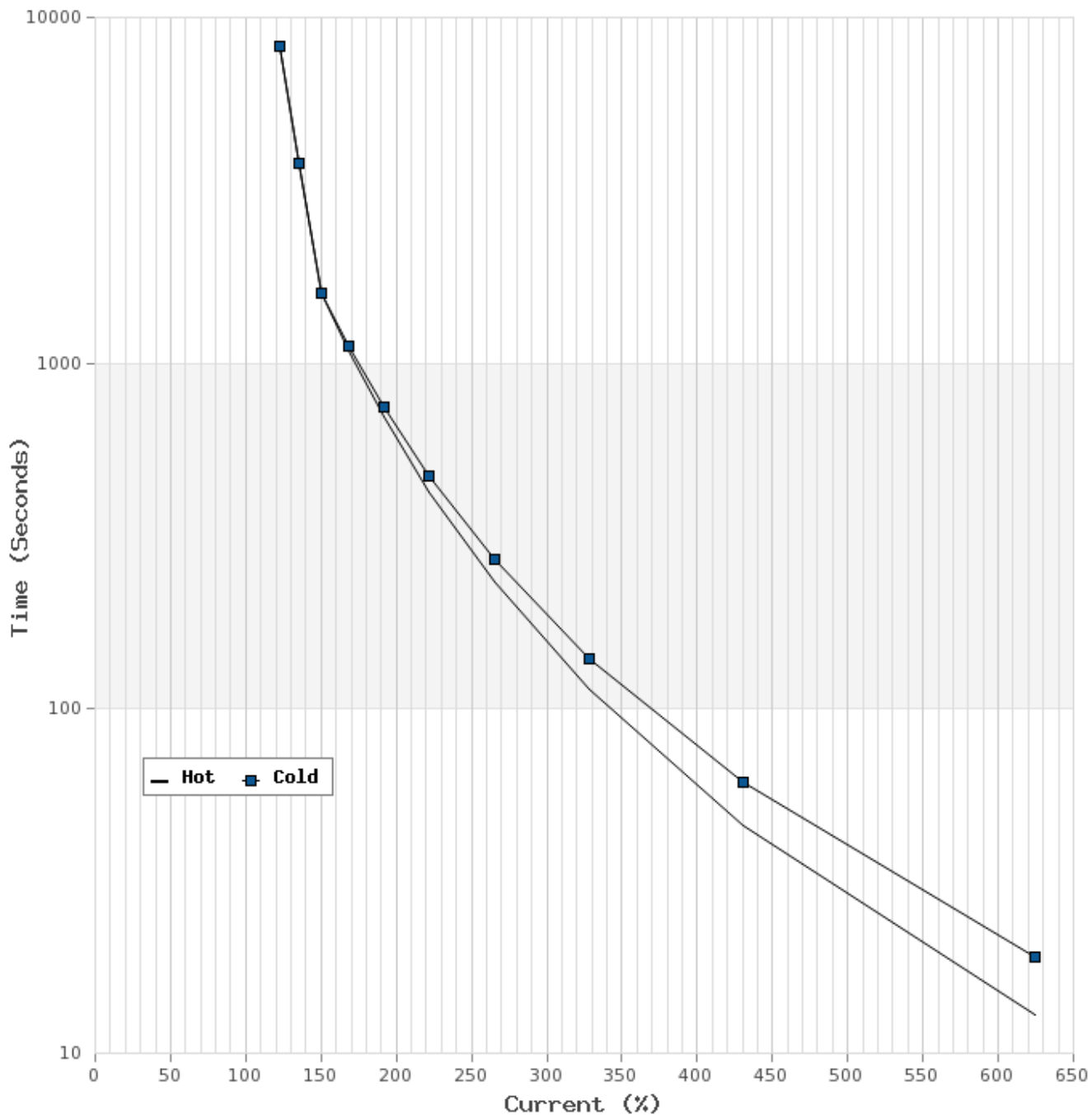

T-N and I-N Curves

Motor Type: AEHH8B		Catalogue No: APH15065-841		Family: Advantage Plus IEEE 841	
HP	150	Full Load T	664.00 lb-ft	Full Load A	140.5 A
Voltage	575V 60Hz	Locked Rotor T	135 %	Locked Rotor A	868.0 A
RPM	1200	Pull Up T	105 %	Break Down T	220 %

