

Technical Documentation

APH02525

Advantage Plus IEEE Ready | AEHH8R

Date: June 26, 2020

Dimensional Drawing

Catalogue	Model	HP	Pole	kW	Rating	Voltage	Hz	RPM
APH02525	AEHH8R	25	2	19	Continuous	575	60	3600

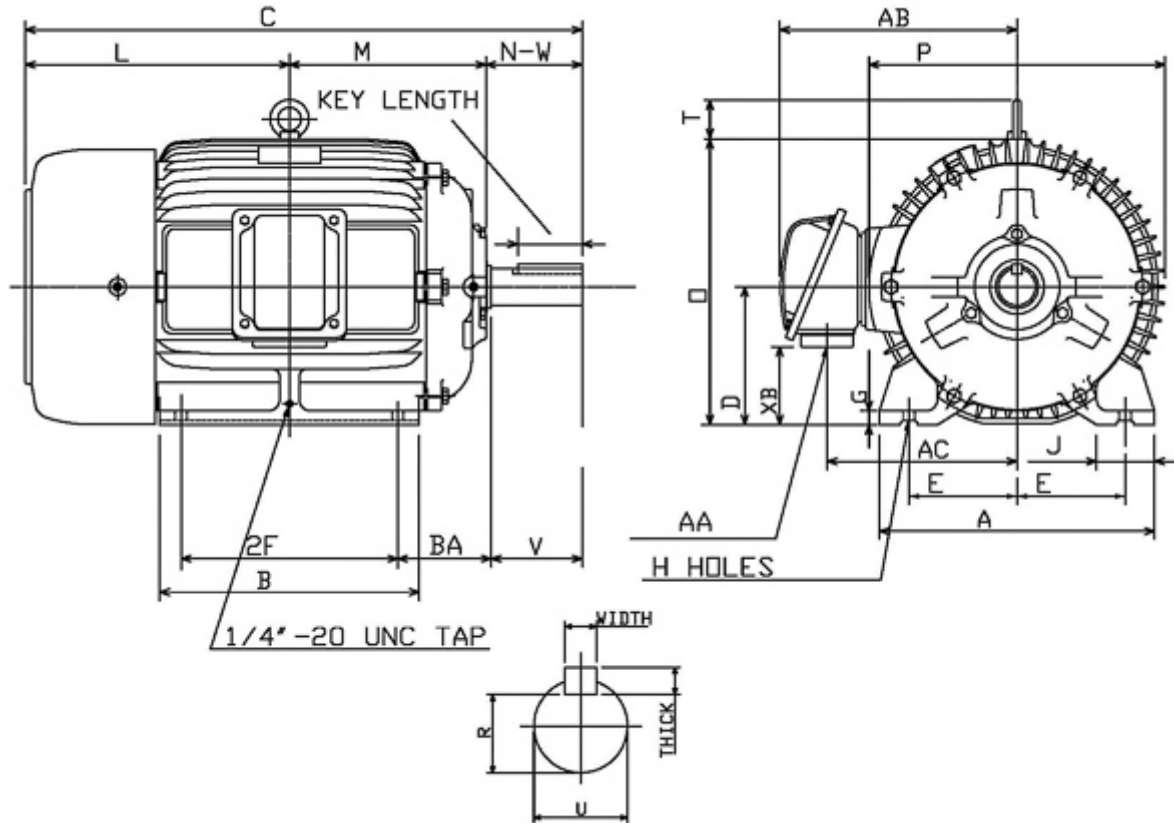

Frame Size	Mounting					A	B	C	CD	D	
	E	2F	2F2	H	BA						
284TS	5.5	9.5		0.53	4.75	13.98	11.69	25.43		7	
G	J	K	L	M	O	P	T	Key			Keyseat R
								Width	Thick	Length	
0.7	2.95		12.68	9.23	14.5	15.05	2.36	0.375	0.375	1.93	1.416
Terminal Housing				Aux Box		C/D Flange					
AA	AB	AC	XB	AE	AX	BB	AH	AK	BD	AJ	BF
NPT11/2"	13.27	10.35	3.54								
Shaft Extension			Bearings		Approx. Weight Lbs	SPL dBA/3ft	Ins. Class	S.F.	Drive Method	Dimensions	
N-W	U	V	DE	NDE							
3.25	1.625	3.2	6311ZC3	6310ZC3	394	76	F	1.15	Direct Coupling	Inches	

	
	Date: June 26, 2020

Technical Data Sheet

Motor Type: AEHH8R	Catalogue No: APH02525
--------------------	------------------------

Nameplate Information

HP	Pole	RPM	Frame	Voltage	Hz	Phase
25	2	3545	284TS	575	60	3
Enclosure	Ins. Class	Service Factor	Time Rating	NEMA Design	Rated Amb.	Rated Altitude
TEFC	F	1.15	Continuous	B	-40 to 40 °C	<1000 m

Typical Performance

Efficiency (%)				Power Factor (%)		
Full Load		3/4 Load	1/2 Load	Full Load	3/4 Load	1/2 Load
Nom.	Min.					
92.4	91.0	93.0	92.4	91.0	90.5	86.5
Torque				Current (A)		
Full Load (lb-ft)	Locked Rotor (% FLT)	Pull Up (% FLT)	Break Down (% FLT)	No Load	Full Load	Locked Rotor
37.03	175	135	250	4.4	22.3	146
NEMA KVA Code	Inertia (WR ²)			Safe Stall Time (s)		Noise Level Sound Press. dB(A)
	Rotor (lb-ft ²)	NEMA Load (lb-ft ²)	Max. Allowable (lb-ft ²)	Cold	Hot	
G	2.507	26.00	75.00	32	22	76

VFD Duty Information

Speed Range			VFD		S.F.
Constant Torque	Variable Torque	Constant Power	Carrier	Type	
6-60Hz	3-60Hz	60-90Hz	≤ 5 kHz	VPWM or CPWM	1.0 Only

Hazardous Locations Information

CSA Certified
Class I, Div 2, Groups B, C & D Class I, Zone 2, Groups IIB+H2, IIB & IIA
Temp Code (Sinewave / VFD)
T3C / T3B

Additional Certifications

Other Certification
Class II, Div 2, Groups F & G

Additional Information

Bearings		Approx. Weight
DE	NDE	lbs
6311ZC3	6310ZC3	394

Nameplate Drawing

Advantage Plus IEEE Ready

TYPE	AEHH8R	CAT. NO.	APH02525		
OUTPUT	25 HP 19 kW	FRAME	284TS	TEFC	
R.P.M.	3545	POLE	2	INS.	F
VOLTS	575	PHASE	3	Hz	60
AMPS	22.3	CODE	G	S.F.	1.15
AMBIENT	40 °C	NOM. EFF. 92.4		MIN. EFF. 91.0	
BEARINGS	6311ZC3 / 6310ZC3			RATING Cont.	
SER. NO.	TBD	DESIGN	B	WT. 394 LBS	
PWM VFD DUTY	VT	CT	CP	S.F.	
	3-60Hz	6-60Hz	60-90Hz	1.0 Only	

Connection Diagram



3 LEAD		SINGLE VOLTAGE			DELTA
VOLTAGE	CONN.	L1	L2	L3	
-	DELTA	1	2	3	

WD_3D

Thermal Limit Curves

Motor Type: AEHH8R		Catalogue No: APH02525		Family: Advantage Plus IEEE Ready	
HP	25	Safe Stall Time		Full Load A	22.3 A
Voltage	575V 60Hz	Hot	22 s	% Inrush	656 %
RPM	3600	Cold	32 s	Locked Rotor A	146 A

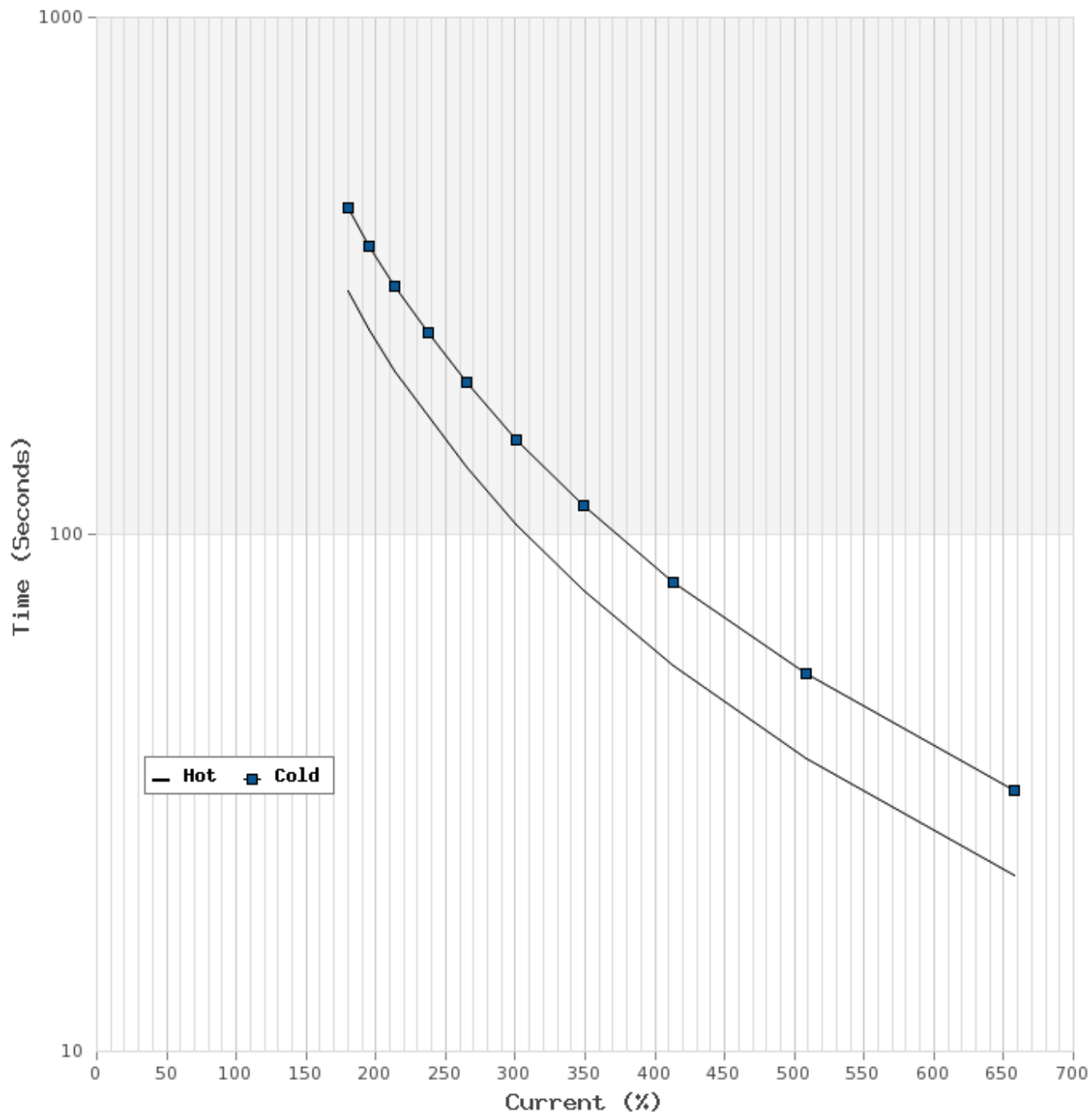

T-N and I-N Curves

Motor Type: AEHH8R		Catalogue No: APH02525		Family: Advantage Plus IEEE Ready	
HP	25	Full Load T	37.03 lb-ft	Full Load A	22.3 A
Voltage	575V 60Hz	Locked Rotor T	175 %	Locked Rotor A	146.0 A
RPM	3600	Pull Up T	135 %	Break Down T	250 %

