

Technical Documentation

# **APH1502-841**

## **Advantage Plus IEEE 841 | AEHH8B**

Date: June 29, 2020

### Dimensional Drawing

Catalogue	Model	HP	Pole	kW	Rating	Voltage	Hz	RPM
APH1502-841	AEHH8B	150	2	112	Continuous	460	60	3600

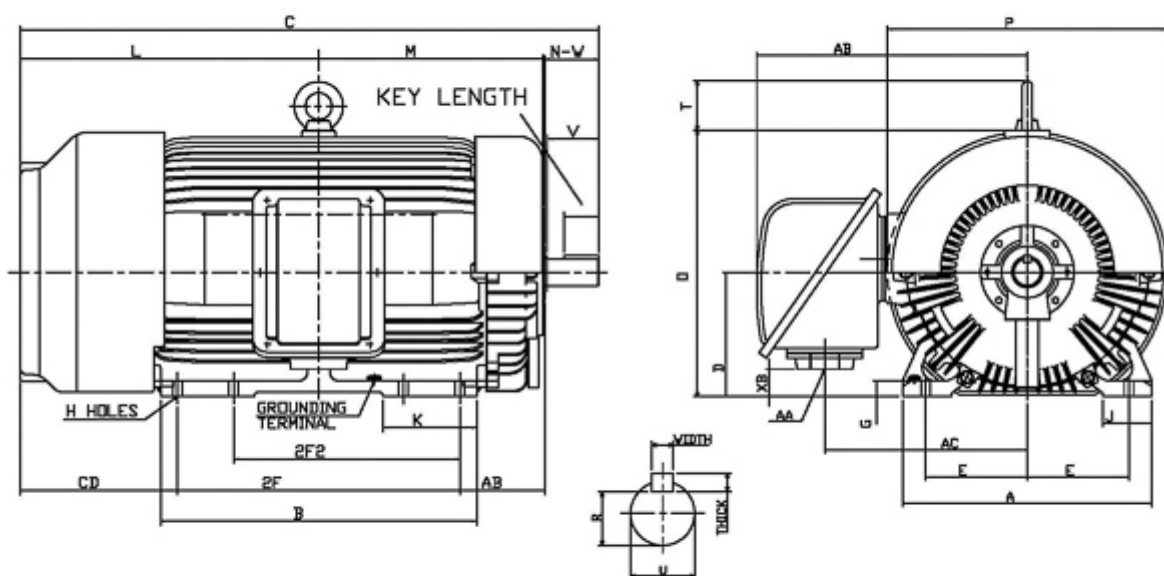

Frame Size	Mounting					A	B	C	CD	D	
	E	2F	2F2	H	BA						
445TS	9	16.5	14.5	0.81	7.5	22.05	19.5	42.65	13.9	11	
G	J	K	L	M	O	P	T	Key			Keyseat
1.4	4.35	5.1	22.15	15.4	23.55	24.75	4.35	Width	Thick	Length	R
								0.625	0.625	3.03	2.021
Terminal Housing			Aux Box			C/D Flange					
AA	AB	AC	XB	AE	AX	BB	AH	AK	BD	AJ	BF
NPT3"	24	17.9	2.4								
Shaft Extension			Bearings		Approx. Weight Lbs	SPL dBA/3ft	Ins. Class	S.F.	Drive Method	Dimensions	
N-W	U	V	DE	NDE							
4.75	2.375	4.5	6314C3	6314C3	1696	83	F	1.15	Direct Coupling	Inches	

	
	Date: June 29, 2020

### Technical Data Sheet

Motor Type: AEHH8B	Catalogue No: APH1502-841
--------------------	---------------------------

#### Nameplate Information

HP	Pole	RPM	Frame	Voltage	Hz	Phase
150	2	3570	445TS	460	60	3
Enclosure	Ins. Class	Service Factor	Time Rating	NEMA Design	Rated Amb.	Rated Altitude
TEFC	F	1.15	Continuous	B	-40 to 40 °C	<1000 m

#### Typical Performance

Efficiency (%)				Power Factor (%)		
Full Load		3/4 Load	1/2 Load	Full Load	3/4 Load	1/2 Load
Nom.	Min.					
95.0	94.1	94.5	93.6	87.0	84.5	81.0
Torque				Current (A)		
Full Load (lb-ft)	Locked Rotor (% FLT)	Pull Up (% FLT)	Break Down (% FLT)	No Load	Full Load	Locked Rotor
220.00	110	88	220	42.0	169.9	1085
NEMA KVA Code	Inertia (WR <sup>2</sup> )			Safe Stall Time (s)		Noise Level Sound Press. dB(A)
	Rotor (lb-ft <sup>2</sup> )	NEMA Load (lb-ft <sup>2</sup> )	Max. Allowable (lb-ft <sup>2</sup> )	Cold	Hot	
G	20.000	133.00	133.00	28	19	83

#### VFD Duty Information

Speed Range			VFD		S.F.
Constant Torque	Variable Torque	Constant Power	Carrier	Type	
12-60Hz	3-60Hz	60-60Hz	≤ 5 kHz	VPWM or CPWM	1.0 Only

#### Hazardous Locations Information

CSA Certified	Other Certification
Class I, Div 2, Groups B, C & D Class I, Zone 2, Groups IIB+H2, IIB & IIA	
Temp Code (Sinewave / VFD)	T3C / T3

#### Additional Certifications

#### Additional Information

Bearings		Approx. Weight
DE	NDE	lbs
6314C3	6314C3	1696

**Nameplate Drawing**

# Advantage Plus IEEE 841

TYPE	AEHH8B	CAT. NO.	APH1502-841		
OUTPUT	150 HP 112 kW	FRAME	445TS	TEFC	
R.P.M.	3570	POLE	2	INS.	F
VOLTS	460	PHASE	3	Hz	60
AMPS	169.9	CODE	G	S.F.	1.15
AMBIENT	40 °C	NOM. EFF. 95.0		MIN. EFF. 94.1	
BEARINGS	6314C3 / 6314C3			RATING Cont.	
SER. NO.	TBD	DESIGN	B	WT. 1696 LBS	
PWM VFD DUTY	VT	CT	CP	S.F.	
	3-60Hz	12-60Hz	60-60Hz	1.0 Only	

**Connection Diagram**



3 LEAD		SINGLE VOLTAGE			DELTA
VOLTAGE	CONN.	L1	L2	L3	
-	DELTA	1	2	3	

WD\_3D

### Thermal Limit Curves

Motor Type: AEHH8B		Catalogue No: APH1502-841		Family: Advantage Plus IEEE 841	
HP	150	Safe Stall Time		Full Load A	169.9 A
Voltage	460V 60Hz	Hot	19 s	% Inrush	638 %
RPM	3600	Cold	28 s	Locked Rotor A	1085 A

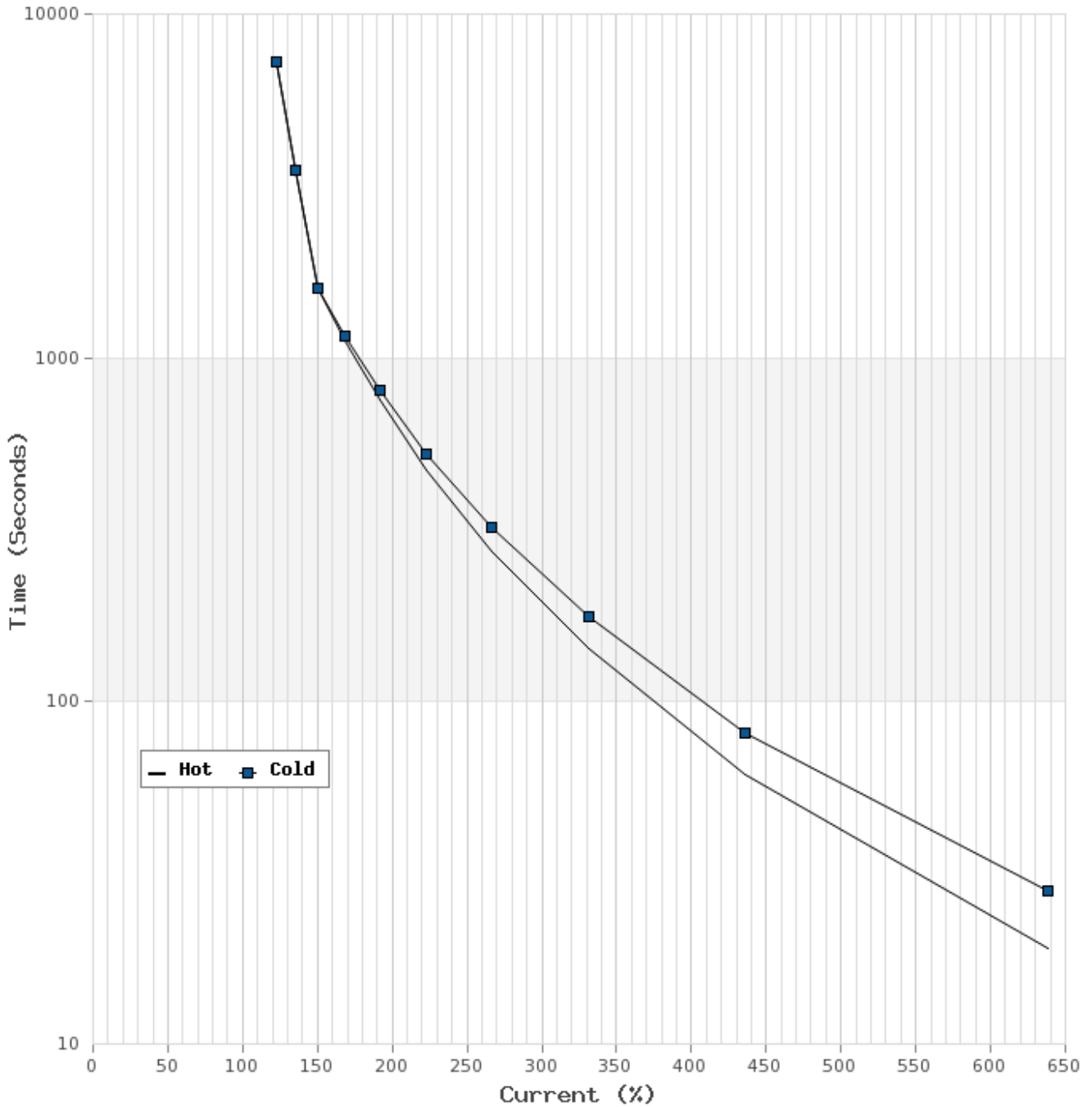

**T-N and I-N Curves**

Motor Type: AEHH8B		Catalogue No: APH1502-841		Family: Advantage Plus IEEE 841	
HP	150	Full Load T	220.00 lb-ft	Full Load A	169.9 A
Voltage	460V 60Hz	Locked Rotor T	110 %	Locked Rotor A	1085.0 A
RPM	3600	Pull Up T	88 %	Break Down T	220 %

