

Technical Documentation

APH00365-841
Advantage Plus IEEE 841 | AEHH8B

Date: June 27, 2020

Dimensional Drawing

Catalogue	Model	HP	Pole	kW	Rating	Voltage	Hz	RPM
APH00365-841	AEHH8B	3	6	2.2	Continuous	575	60	1200

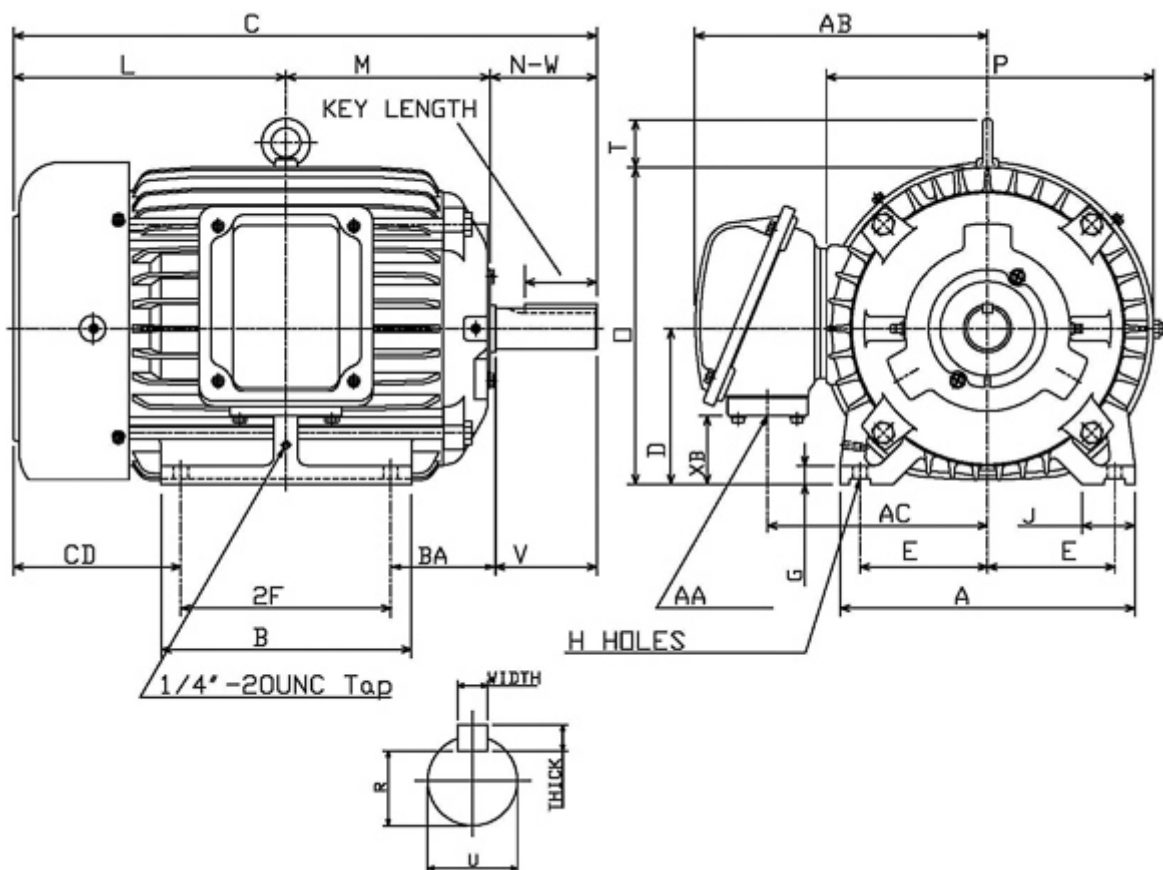

Frame Size	Mounting					A	B	C	CD	D	
	E	2F	2F2	H	BA						
213T	4.25	5.5		0.41	3.5	9.85	6.89	18.26		5.25	
G	J	K	L	M	O	P	T	Key			Keyseat
0.7	1.75		8.63	6.1	10.62	11.1	1.65	Width	Thick	Length	R
								0.312	0.312	2.41	1.201
Terminal Housing			Aux Box			C/D Flange					
AA	AB	AC	XB	AE	AX	BB	AH	AK	BD	AJ	BF
NPT1"	9.78	7.34	2.34								
Shaft Extension			Bearings		Approx. Weight Lbs	SPL dBA/3ft	Ins. Class	S.F.	Drive Method	Dimensions	
N-W	U	V	DE	NDE							
3.38	1.375	3.3	6308ZC3	6306ZC3	165	54	F	1.15	Direct Coupling / Belt Drive	Inches	

	
	Date: June 27, 2020

Technical Data Sheet

Motor Type: AEHH8B	Catalogue No: APH00365-841
--------------------	----------------------------

Nameplate Information

HP	Pole	RPM	Frame	Voltage	Hz	Phase
3	6	1175	213T	575	60	3
Enclosure	Ins. Class	Service Factor	Time Rating	NEMA Design	Rated Amb.	Rated Altitude
TEFC	F	1.15	Continuous	B	-40 to 40 °C	<1000 m

Typical Performance

Efficiency (%)				Power Factor (%)		
Full Load		3/4 Load	1/2 Load	Full Load	3/4 Load	1/2 Load
Nom.	Min.					
89.5	87.5	89.5	87.5	78.0	70.5	85.5
Torque				Current (A)		
Full Load (lb-ft)	Locked Rotor (% FLT)	Pull Up (% FLT)	Break Down (% FLT)	No Load	Full Load	Locked Rotor
13.41	210	180	340	1.7	3.2	26
NEMA KVA Code	Inertia (WR ²)			Safe Stall Time (s)		Noise Level Sound Press. dB(A)
	Rotor (lb-ft ²)	NEMA Load (lb-ft ²)	Max. Allowable (lb-ft ²)	Cold	Hot	
K	0.918	44.00	378.00	88	62	54

VFD Duty Information

Speed Range			VFD		S.F.
Constant Torque	Variable Torque	Constant Power	Carrier	Type	
6-60Hz	3-60Hz	60-120Hz	≤ 5 kHz	VPWM or CPWM	1.0 Only

Hazardous Locations Information

CSA Certified	
Class I, Div 2, Groups B, C & D Class I, Zone 2, Groups IIB+H2, IIB & IIA	
Temp Code (Sinewave / VFD)	T3C / T3C

Additional Certifications

Other Certification

Additional Information

Bearings		Approx. Weight
DE	NDE	lbs
6308ZC3	6306ZC3	165

Nameplate Drawing

Advantage Plus IEEE 841

TYPE	AEHH8B	CAT. NO.	APH00365-841		
OUTPUT	3 HP 2.2 kW	FRAME	213T	TEFC	
R.P.M.	1175	POLE	6	INS.	F
VOLTS	575	PHASE	3	Hz	60
AMPS	3.2	CODE	K	S.F.	1.15
AMBIENT	40 °C	NOM. EFF. 89.5		MIN. EFF. 87.5	
BEARINGS	6308ZC3 / 6306ZC3			RATING Cont.	
SER. NO.	TBD	DESIGN	B	WT. 165 LBS	
PWM VFD DUTY	VT	CT	CP	S.F.	
	3-60Hz	6-60Hz	60-120Hz	1.0 Only	

Connection Diagram

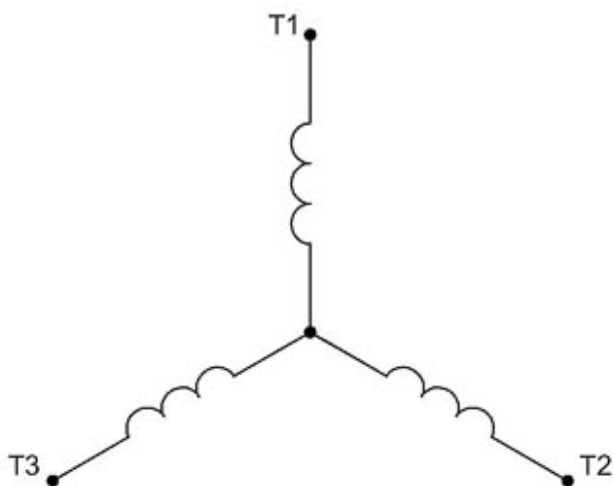

3 LEAD		SINGLE VOLTAGE			WYE
VOLTAGE	CONN.	L1	L2	L3	
-	WYE	1	2	3	

WD_3Y

Thermal Limit Curves

Motor Type: AEHH8B		Catalogue No: APH00365-841		Family: Advantage Plus IEEE 841	
HP	3	Safe Stall Time		Full Load A	3.2 A
Voltage	575V 60Hz	Hot	62 s	% Inrush	807 %
RPM	1200	Cold	88 s	Locked Rotor A	26 A

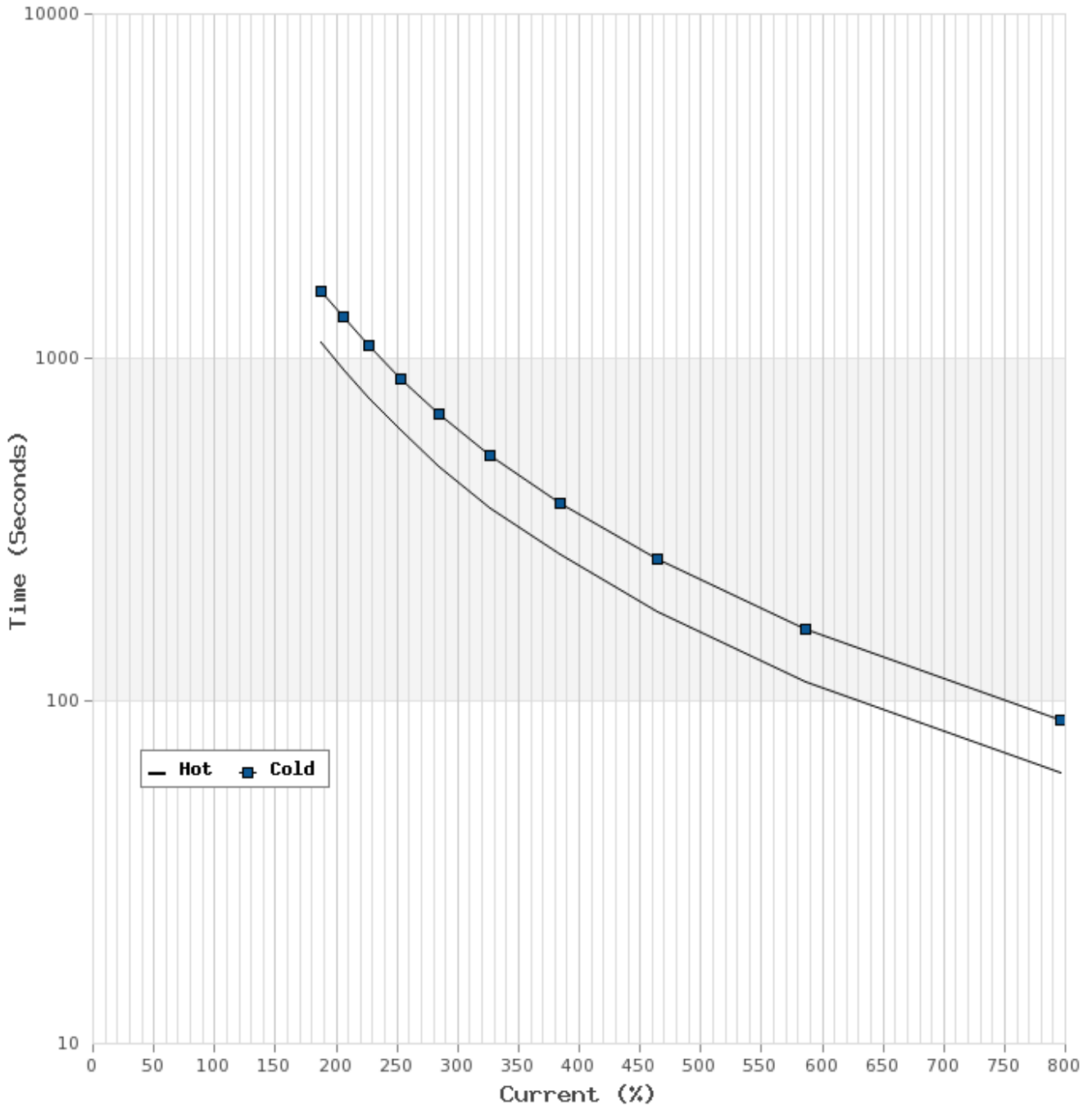

T-N and I-N Curves

Motor Type: AEHH8B		Catalogue No: APH00365-841		Family: Advantage Plus IEEE 841	
HP	3	Full Load T	13.41 lb-ft	Full Load A	3.2 A
Voltage	575V 60Hz	Locked Rotor T	210 %	Locked Rotor A	26.0 A
RPM	1200	Pull Up T	180 %	Break Down T	340 %

